

OfficeServ 7100
Installation Manual



COPYRIGHT

This manual is proprietary to SAMSUNG Electronics Co., Ltd. and is protected by copyright. No information contained herein may be copied, translated, transcribed or duplicated for any commercial purposes or disclosed to the third party in any form without the prior written consent of SAMSUNG Electronics Co., Ltd.

TRADEMARKS

Enterprise IP Solutions

OfficeServTM is the trademark of SAMSUNG Electronics Co., Ltd.

Product names mentioned in this manual may be trademarks and/or registered trademarks of their respective companies.

This manual should be read and used as a guideline for properly installing and operating the product.

This manual may be changed for the system improvement, standardization and other technical reasons without prior notice.

If you need updated manuals or have any questions concerning the contents of the manuals, contact our **Document Center** at the following address or Web site:

Address: Document Center 18th Floor IT Center. Dong-Suwon P.O. Box 105, 416, Maetan-3dong Yeongtong-gu, Suwon-si, Gyeonggi-do, Korea 442-600

Homepage: <http://www.samsungdocs.com>

INTRODUCTION

Purpose

OfficeServ 7100 is the most suitable system for offices using circuit lines with 10 to 25 subscribers. This manual describes the condition for OfficeServ 7100 system installation and how to install, inspect and operate the system.

Document Content and Organization

This document consists of eight chapters, and abbreviations as follows:

CHAPTER 1. Before Installing

This chapter describes the checklists, such as the installation site and the grounding & the power conditions, to be inspected before installing the OfficeServ 7100 system. This chapter also describes the items included in the OfficeServ 7100 package and the installation procedure.

CHAPTER 2. Installing Cabinets

This chapter describes how to install an OfficeServ 7100 cabinet on the ground or inside a rack, depending on the installation environment, and how to connect the grounding wire.

CHAPTER 3. Mounting and Replacing Boards

This chapter describes how to mount or replace various boards of the OfficeServ 7100 system.

CHAPTER 4. Connecting External Batteries

This chapter describes how to connect an external battery to the OfficeServ 7100 system.

CHAPTER 5. Connecting the Power

This chapter describes how to connect the power to the OfficeServ 7100 system.

CHAPTER 6. Connecting C.O. Lines

This chapter describes how to connect C.O. lines to the OfficeServ 7100 system.

CHAPTER 7. Connecting Stations and Additional Equipment

This chapter describes how to connect various stations and additional equipment, such as analog/digital phones, door phones and door locks, to the OfficeServ 7100 system.

CHAPTER 8. Starting the System

This chapter describes items to check before starting the OfficeServ 7100 system, the procedure for starting the system, and the procedure for testing whether the system is normally operating after startup.

ABBREVIATION

Abbreviations frequently used in this document are described.

Conventions

The following types of paragraphs contain special information that must be carefully read and thoroughly understood. Such information may or may not be enclosed in a rectangular box, separating it from the main text, but is always preceded by an icon and/or a bold title.



WARNING

Provides information or instructions that the reader should follow in order to avoid personal injury or fatality.



CAUTION

Provides information or instructions that the reader should follow in order to avoid a service failure or damage to the system.



CHECKPOINT

Provides the operator with checkpoints for stable system operation.



NOTE

Indicates additional information as a reference.

Reference

OfficeServ 7100 System Manual

This document introduces OfficeServ 7100 and describes the system information, such as hard configuration, specification, and functions, necessary for this system.

OfficeServ 7100 Programming Manual

This document describes how to use the MMC program to change the OfficeServ 7100 system setting by using a phone.

Revision History

EDITION	DATE OF ISSUE	REMARKS
00	08. 2006.	Original Draft
01	01.2007	Safety, VM and Router etc.



This page is intentionally left blank.

SAFETY CONCERNS

For product safety and correct operation, the following information must be given to the operator/user and shall be read before the installation and operation.

Symbols

**Caution**

Indication of a general caution

**Restriction**

Indication for prohibiting an action for a product

**Instruction**

Indication for commanding a specifically required action

WARNING



Caution for Grounding

- Do not connect the grounding wire of the OfficeServ 7100 system to a power conduit of a building
- The standards for power and grounding should comply with the country standard and the pertinent work should be conducted according to the country standard.
- External grounding is required to prevent human injuries or system damages caused by lightning, static electricity, or voltage surge.
- Unplug the AC power cord before connecting the grounding wire. Failure to do so may cause human injury.
- The OfficeServ 7100 system should be connected to an outlet with a protective ground.
- The GND in the back panel of the OfficeServ 7100 system should be grounded.



Use of Double-pole/neutral fusing

If the system is repaired after removing only one fuse used in the neutral line, it may cause electric shock. If the repair is required, repair the system after extracting the plug of the power cord.



Caution for powers when mounting boards

Check if the cabinet power is off when mounting boards on slots. Inserting or ejecting a board while the power is on may damage the board.



Caution for the connection of the ground cable

Unplug the AC power cord before connecting the ground cable. If the connection work is performed when the power cable is connected, it may cause serious bodily damage.



CAUTION



Caution for Installation

Only a trained service staff can install the OfficeServ 7100 system.

The equipment intended only for installation in a **RESTRICTED ACCESS LOCATION**



Caution for the connection of External Batteries

Do not connect an external AC power until the battery and the system is completely disconnected. To do so may cause electric shock to the constructor or the system.

Make sure that the specified polarities(+, -) are correctly connected when connecting external batteries.

To reduce risk of fire and injury to persons, use only a sealed nickel cadmium or lead-acid battery supply capable of handling a charge current of 0.25 A, a charge voltage of -54 V dc and a discharge rate of 26 Ah.







Leakage currents due to ringing voltage - Earthing installation instructions

"1.A supplementary equipment earthing conductor is to be installed between the product or system and earth, that is, in addition to the equipment earthing conductor in the power supply cord.

2.The supplementary equipment earthing conductor may not be smaller in size than the unearthed branch-circuit supply conductors. The supplementary equipment earthing conductor is to be connected to the product at the terminal provided, and connected to earth in a manner that will retain the earth connection when the power supply cord is unplugged. The connection to earth of the supplementary earthing conductor shall be in compliance with the appropriate rules for terminating bonding jumpers in Part K of Article 250 of the National Electrical Code, ANSI/NFPA 70 and Article 10 of Part 1 of the Canadian Electrical Code, Part 1, C22.1. Termination of the supplementary earthing conductor is permitted to be made to building steel, to a metal electrical raceway system, or to any earthed item that is permanently and reliably connected to the electrical service equipment earthed.

3.Bare, covered, or insulated earthing conductors are acceptable. A covered or insulated conductor must have a continuous outer finish that is either green, or green with one or more yellow stripes."

 <p>Separation of TNV and SELV - Pluggable A</p>	<p>"The separate protective earthing terminal provided on this product shall be permanently connected to earth." (Instruction)</p>
 <p>Telephone line cord</p>	<p>"CAUTION: To reduce the risk of fire, use only No. 26 AWG or larger (e.g., 24 AWG) UL Listed or CSA Certified Telecommunication Line Cord"</p>
 <p>Safety Instructions - Rack Mount</p>	<p>"Rack Mount Instructions - The following or similar rack-mount instructions are included with the installation instructions:</p> <ul style="list-style-type: none">A) Elevated Operating Ambient - If installed in a closed or multi-unit rack assembly, the operating ambient temperature of the rack environment may be greater than room ambient. Therefore, consideration should be given to installing the equipment in an environment compatible with the maximum ambient temperature (T_{ma}) specified by the manufacturer.B) Reduced Air Flow - Installation of the equipment in a rack should be such that the amount of air flow required for safe operation of the equipment is not compromised.C) Mechanical Loading - Mounting of the equipment in the rack should be such that a hazardous condition is not achieved due to uneven mechanical loading.D) Circuit Overloading - Consideration should be given to the connection of the equipment to the supply circuit and the effect that overloading of the circuits might have on over-current protection and supply wiring. Appropriate consideration of equipment nameplate ratings should be used when addressing this concern.E) Reliable Earthing - Reliable earthing of rack-mounted equipment should be maintained. Particular attention should be given to supply connections other than direct connections to the branch circuit (e.g. use of power strips)."

	<p>Prohibition of Metal Accessories</p> <p>Do not wear metal accessories such as rings and watches to prevent electric damages to the system.</p>
---	--



Un-allowed Use of Selector Switch

The OfficeServ 7100 system only use 230 V. Do not change the input power freely by means of the selector switch.



AC Power Connection Inhibited

Do not operate other devices with the AC power of the OfficeServ 7100 system or with the DC power of external batteries.



Check of Power-off

Check if the cabinet power is off when mounting boards on slots. Inserting or ejecting a board while the power is on may damage the board.



Board Reset

New settings are applied only after the board is reset. The system may malfunction if the board is not properly initialized.



Caution for Installation

Only a trained service staff can install the OfficeServ 7100 system.



This page is intentionally left blank.

TABLE OF CONTENTS

INTRODUCTION	I
Purpose	I
Document Content and Organization.....	I
Conventions.....	II
Reference	III
Revision History.....	III
SAFETY CONCERNS	V
Symbols.....	V
Warning.....	VI
Caution	VII
CHAPTER 1. Before Installing	1-16
1.1 Site Information	1-16
1.1.1 Safety Conditions	1-16
1.1.2 Temperature and Humidity.....	1-16
1.2 Grounding Conditions	1-16
1.3 Power Conditions	1-16
1.4 Checking the Package	1-16
CHAPTER 2. Installing Cabinets	2-16
2.1 Procedure for the System Installation	2-16
2.2 Selecting Installation Method	2-16
2.3 Installing in a Rack	2-16
2.3.1 Cautions for Installation.....	2-16
2.3.2 Tools Required	2-16
2.3.3 Installing in a Rack	2-16
2.4 Installing on a Wall	2-16
2.4.1 Tools Required	2-16
2.4.2 Installing on a Wall	2-16

2.5	Connecting the Grounding Wire	2-16
CHAPTER 3. Mounting and Replacing Boards		3-16
3.1	Cabinet Configuration	3-16
3.2	Mounting Control Boards	3-16
3.2.1	Setting Switches and Mounting Option Boards	3-16
3.2.2	Mounting Control Boards	3-16
3.3	Mounting Interface Boards	3-16
3.3.1	Setting Switches and Mounting Optional Boards	3-16
3.3.2	Mounting Interface Boards to Slots	3-16
3.4	Connecting Power Fail Transfer	3-16
3.5	Replacing Boards	3-16
CHAPTER 4. Connecting External Batteries		4-16
4.1	Cautions for Connecting External Batteries	4-16
4.2	Connecting External Batteries	4-16
CHAPTER 5. Connecting the Power		5-16
5.1	Cautions when Connecting Power	5-16
5.2	Connecting the Power	5-16
CHAPTER 6. Connecting C.O. Line		6-16
6.1	Line Conditions	6-16
6.2	Connecting the C.O. Line	6-16
6.2.1	Cautions to Connect the C.O. Line	6-16
6.2.2	Connecting Common C.O. Line	6-16
6.2.3	Connecting T1/E1/PRI	6-16
CHAPTER 7. Connecting Stations and Additional Equipment		7-16
7.1	Connecting Stations	7-16
7.1.1	Cautions for Connecting Stations	7-16
7.1.2	Connecting Analog Phones	7-16
7.1.3	Connecting Digital Phones	7-16
7.1.4	Connecting IP Phones	7-16
7.1.5	Connecting to a Door Phone and a Door Lock	7-16

7.2	Connecting Additional Equipment	7-16
7.2.1	Connecting MOH/BGM Equipment	7-16
7.2.2	Connecting External/Additional Page Equipment.....	7-16
7.2.3	Connecting Common Bell	7-16
7.2.4	Changing System Setting	7-16
7.2.5	Connecting SMDR	7-16
7.2.6	Connecting Printers.....	7-16

CHAPTER 8. Starting the System	8-16
---------------------------------------	-------------

8.1	Pre-Check	8-16
8.1.1	Environment	8-16
8.1.2	Safety Conditions	8-16
8.2	Starting the System	8-16
8.3	Numbering Extensions and C.O. Lines	8-16
8.4	Checking System Operation	8-16
8.4.1	Station Call Function	8-16
8.4.2	Station Camp-On Function.....	8-16
8.4.3	C.O. Line Call Function	8-16
8.4.4	C.O. Line Camp-On Function	8-16

ABBREVIATION	XVI
---------------------	------------

4 ~ I	XVI
K ~ W	XVI

LIST OF FIGURES

Figure 2.1	Tools for the Installation inside a Rack	2-16
Figure 2.2	Rack Installation (1)	2-16
Figure 2.3	Rack Installation (2)	2-16
Figure 2.4	Rack Installation (3)	2-16
Figure 2.5	Required Tools for the installation on a Wall	2-16
Figure 2.6	Installation on a Wall (1).....	2-16
Figure 2.7	Installation on a Wall (2).....	2-16
Figure 2.8	Installation on a Wall (3).....	2-16
Figure 2.9	Installation on a Wall (4).....	2-16
Figure 2.10	Installation on a Wall (5).....	2-16
Figure 2.11	Installation on a Wall (6).....	2-16
Figure 2.12	Installation on a Wall (7).....	2-16
Figure 2.13	Grounding	2-16
Figure 3.1	Front/rear View of OfficeServ 7100 Cabinet.....	3-16
Figure 3.2	Setting Switches of MP10/11 Board	3-16
Figure 3.3	Mounting a Modem Board on the MP10/11 Board	3-16
Figure 3.4	Mounting the Control Board to Slot 0	3-16
Figure 3.5	Inserting the Control Board to a connector of the Main Board	3-16
Figure 3.6	Mounting the UNI Board	3-16
Figure 3.7	Setting the Switch of the TEPRI Board	3-16
Figure 3.8	Setting Switches of the TEPRI2 Board	3-16
Figure 3.9	PLIM Board	3-16
Figure 3.10	Mounting an Interface Board on a Slot.....	3-16
Figure 3.11	Inserting a control Board to the Connector of the Main Board.....	3-16
Figure 3.12	Connecting Power Fal Connection to a 16SLI2/8SLI Board	3-16
Figure 3.13	Turning the Cabinet Power Off.....	3-16
Figure 3.14	Removing a Board	3-16
Figure 3.15	Replacing a New Board	3-16
Figure 4.1	Connecting an External Battery.....	4-16
Figure 5.1	Connecting the Power (use of a cabinet).....	5-16
Figure 6.1	RJ-45 Port of 4TRM//8TRK Board	6-16
Figure 6.2	RJ-45 Port of 2BRM Board	6-16
Figure 6.3	RJ-45 Port of TEPRI Board.....	6-16
Figure 7.1	RJ-45 Port of 4SLM Board.....	7-16
Figure 7.2	RJ-45 Port of 16SLI2 Board	7-16
Figure 7.3	RJ-45 Port of 8COMBO Board (for Analog Phone Connection).....	7-16
Figure 7.4	RJ-45 Port of 4DLM Board.....	7-16

Figure 7.5	RJ-45 Port of a 8DLI (for a digital phone).....	7-16
Figure 7.6	RJ-45 Port of 8COMBO Board (for digital phone)	7-16
Figure 7.8	IP Phone Layout.....	7-16
Figure 7.9	RJ-45 Port of Ethernet Connection Board	7-16
Figure 7.10	RJ-45 Port of 8DLI/16DLI2/8COMBO/4DLM Boards (for Door Phone)	7-16
Figure 7.11	Connecting MOH/BGM Sources.....	7-16
Figure 7.12	Connecting External/Additional Page Equipment.....	7-16
Figure 7.13	Connecting Common Bells.....	7-16
Figure 7.14	WebMMC Initial Screen.....	7-16
Figure 7.15	Connecting SMDR.....	7-16
Figure 7.16	Connecting Printers.....	7-16

LIST OF TABLES

Table 1.1	Power Standards.....	1-16
Table 1.2	Package Items	1-16
Table 3.1	Mountable Boards on Slots	3-16
Table 3.2	Parts on the Rear Panel of the Cabinet	3-16
Table 3.3	Switches of MP10/11 Board.....	3-16
Table 3.4	Control Board Types	3-16
Table 3.5	Interface Board for Switch/Jumper Setting.....	3-16
Table 3.6	Interface Boards that can mount option boards	3-16
Table 3.7	Interface Board Types and Available Slots.....	3-16
Table 6.1	Line condition of OfficeServ 7100	6-16
Table 7.1	Distance Between Stations and the System	7-16
Table 7.2	Specification of the SMDR System	7-16



This page is intentionally left blank.

CHAPTER 1. Before Installing

This chapter describes items to check when inspecting the installation site and the grounding and power conditions before installing the OfficeServ 7100 system. This chapter also describes the items included in the OfficeServ 7100 package and the installation procedure.

1.1 Site Information

Select a site that satisfies the following conditions for safety, temperature and humidity:

1.1.1 Safety Conditions

- The OfficeServ 7100 system should not be installed near materials that can cause a fire, such as explosive gas and inflammables.
- The OfficeServ 7100 system should not be near equipments that generate electromagnetic waves, such as monitors or copying machines.
- The installation location should be convenient for distributing trunk lines and extension lines, for connecting power and grounding wires, and for maintenance and repair.
- The OfficeServ 7100 system should not be installed in aisles or passageways that are populated or used for moving equipment.
- Always maintain cleanliness to prevent dust from damaging the board-connecting part of the cabinet.
- Before installing the OfficeServ 7100 system, check items such as the electric wiring status, grounding status, voltage and frequency.

1.1.2 Temperature and Humidity

- The conditions for temperature and humidity are as follows:
 - Operation Temperature: 0~40°C
 - Storage temperature: -10~50°C
 - Humidity: 10~90%
- Cool area without direct sunlight
- Ventilators should be installed to remove dust.

1.2 Grounding Conditions

- The following cautions should be taken when grounding the OfficeServ 7100 system:
- The grounding wire of the OfficeServ 7100 system should be grounded to the earth using a proper material.
- The flow of electric current between the grounding wire of the power plug and the exposed metal surface of the system should be satisfactory.
- When connecting grounding of external additional equipments to the grounding of the system, the groundings should be connected through a single connection point.



Cautions for Grounding

- Do not connect the grounding wire of the OfficeServ 7100 system to a power conduit of a building.
- The standards for power and grounding should comply with the country standard and the pertinent work should be conducted according to the country standard.
- External grounding is required to prevent human injuries or system damages caused by lightning, static electricity, or voltage surge.
- Unplug the AC power code before connecting the ground line. Failure to do so may cause bodily damage.
- OfficeServ 7100 System should be connected to an outlet with a protective ground.
- The GND in the back of the OfficeServ 7100 system should be grounded.

1.3 Power Conditions

The power supply board of the OfficeServ 7100 system receives AC input power or battery power, and supplies -54 V, -5 V, +5 V, +3.3 V, +12 V, and -54 V(Battery) to the system cabinet.

The power condition is as follows:

- AC 220-240V, 1.5 A, 50/60 Hz, or DC 48 V, 3 A

Table 1.1 Power Standards

Power Supply		Standards
Power Supply Unit(PSU)	Input Power	AC 230 V
	Output Power	- DC -54 V, 1.1 A - DC +5 V, 5 A - DC -5.3 V, 0.3 A - DC +3.3 V, 5 A - DC +12 V, 0.4 A - DC -54 V, 0.25 A(for backup)

1.4 Checking the Package

The list of items included in the OfficeServ 7100 package is as follows:

Table 1.2 Package Items

Category	Name	Quantity	Remark
Cabinet	Basic Cabinet	1	-
Cable	Power Cable	1	-
	Battery Cable	1	-
Items for 19" Rack Installation	Bracket for attaching Cabinet	1	
	Screws for attaching Cabinet	3	
	Other Screws	2	
Others	Blank stiffener	1	



NOTE

UTP Cable Types

Available UTP cables are Straight-through UTP cable and Crossover UTP cable. The Straight-through UTP cable is used for connecting LIM module of the OfficeServ 7100 system to other modules such as MP10/11 and MGI. The Crossover UTP cable is only used for the connection between the LIM modules.



This page is intentionally left blank.

CHAPTER 2. Installing Cabinets

This chapter describes how to install an OfficeServ 7100 cabinet on the ground, inside rack or on a wall depending on the installation environment.

2.1 Procedure for the System Installation

The procedure of system installation is as follows:

- 1) Install the cabinet on the ground, inside rack or on a wall depending on the installation environment.
- 2) Ground to the ground lug behind the basic cabinet.
- 3) Insert the MP10/11 board into the slot 0 of the basic cabinet.
- 4) Insert various interface boards into the universal slots(slot 1 and slot 2).
- 5) Connect an external battery.
- 6) Connect input power of AC 230 V..

2.2 Selecting Installation Method

The OfficeServ 7100 cabinet can be installed on the ground, inside a 19-inch rack or on a wall depending on the number of cabinets and environment of the installation area.

2.3 Installing in a Rack

This section describes how to install the OfficeServ 7100 cabinet inside a 19-inch rack.

2.3.1 Cautions for Installation

Take the following cautions when installing the OfficeServ 7100 cabinet inside a rack:

- The 19" rack should be a standard electric equipment rack.
- When using an enclosed-type rack, check if the rack is properly ventilated. Vents should be equipped on the side of the rack and fans should be attached to ventilate cool air into the rack.
- For the enclosed-type rack that the fan is attached on the top, beware that the hot-air generated in the system on the bottom part can go up and enters to the inlet port of the installed system.
- When using an open rack, do not block the entrance of a port or fan of the OfficeServ 7100 system.

2.3.2 Tools Required

- A middle-sized Phillips screwdriver
- Two brackets and six screws for attaching rack
- Two clamp screws

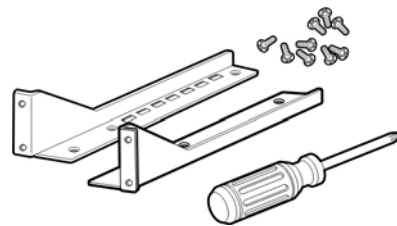

Figure 2.1 Tools for the Installation inside a Rack

2.3.3 Installing in a Rack

The procedure for installing the OfficeServ 7100 cabinet inside a 19-inch rack is as follows:

- 1) Attach the cabinet bracket to the bottom surface of the OfficeServ 7100 cabinet and fasten the bracket firmly with the two screws.

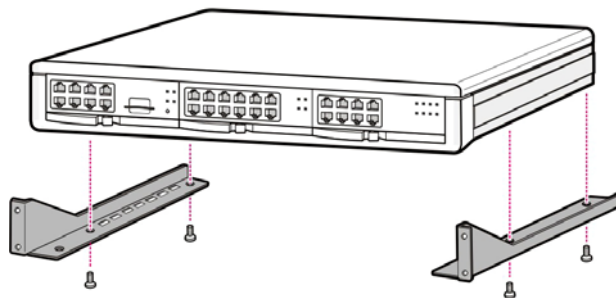

Figure 2.2 Rack Installation (1)

2) Slide the cabinet attaching the bracket in Step 1.

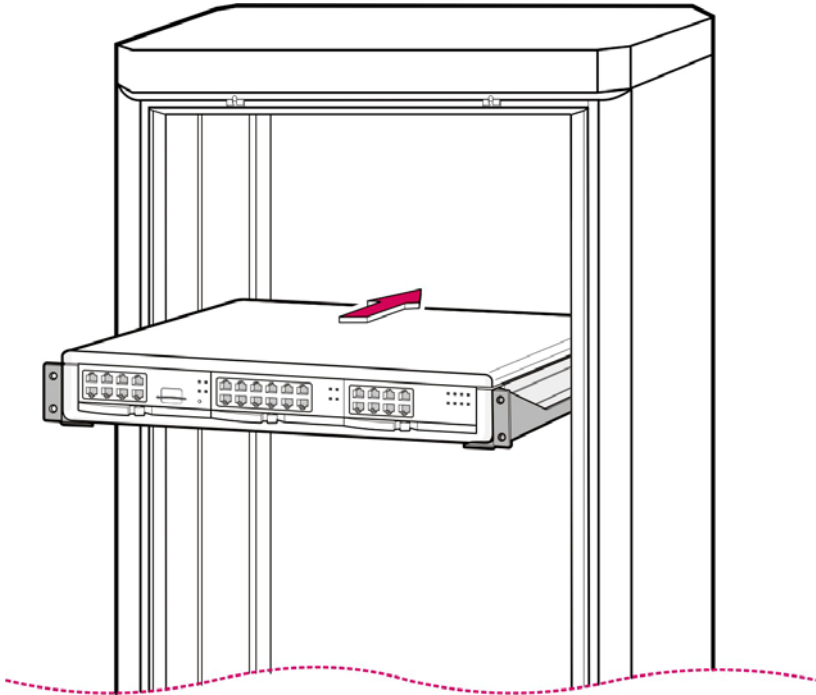

Figure 2.3 Rack Installation (2)

3) Align the two holes of the cabinet bracket and the holes of the rack brackets, and fasten the cabinet to the rack with the two screws.

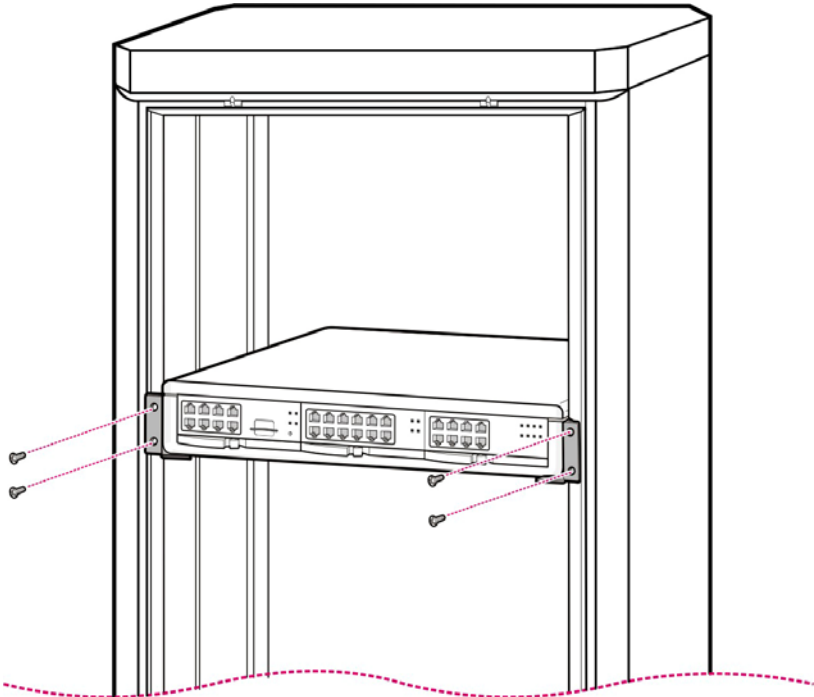

Figure 2.4 Rack Installation (3)

2.4 Installing on a Wall

This section describes how to install the OfficeServ 7100 cabinet on a wall.

2.4.1 Tools Required

- Mid-sized Phillips screw driver
- Electric drill
- Hammer
- Wall-type bracket
- Four plastic anchors
- Four cross-type screws
- Four Mount locking screws

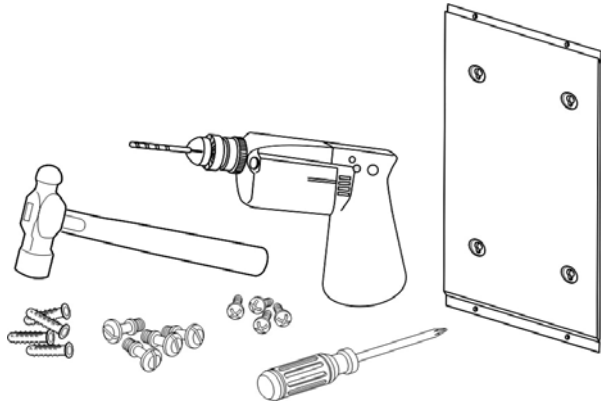

Figure 2.5 Required Tools for the installation on a Wall

2.4.2 Installing on a Wall

The way to install the OfficeServ 7100 cabinet by using a wall-type bracket is as follows:

- 1) There are four holes for the screws on the top/bottom of the bracket(A positions of the figure below). Mark four holes on a desired wall by using the bracket.

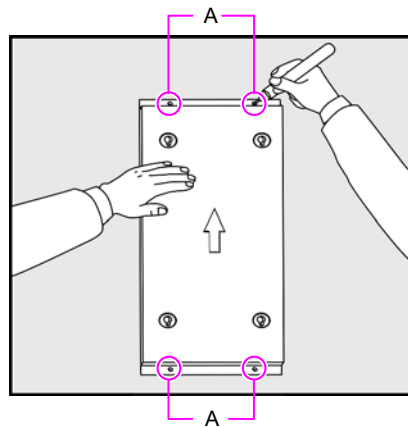

Figure 2.6 Installation on a Wall (1)

- 2) Make holes on the marked position of the wall-type bracket. Make the depths and the diameters of the holes more than 35 mm and around 5.5 mm to enable to insert the plastic anchors easily, respectively.

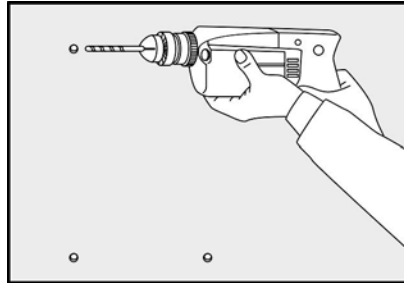

Figure 2.7 Installation on a Wall (2)

- 3) With a hammer, drive plastic anchors into the drilled holes.

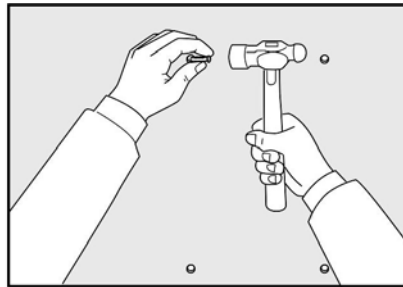

Figure 2.8 Installation on a Wall (3)

- 4) Align the screw holes of the wall-type bracket to the position that the plastic anchors are driven. Insert screws to each hole and tighten the screws with a philips screw driver.

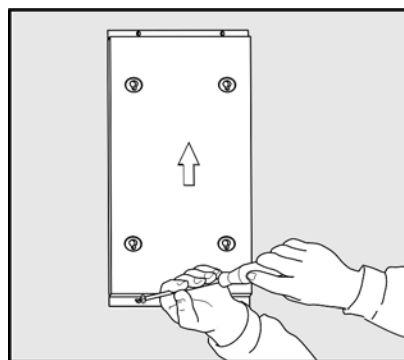

Figure 2.9 Installation on a Wall (4)

- 5) Two screws exist into the two screw holes among the four screw holes on the bottom side of the OfficeServ 7100 cabinet. Unscrew two screws with a screw driver about 2 mm.

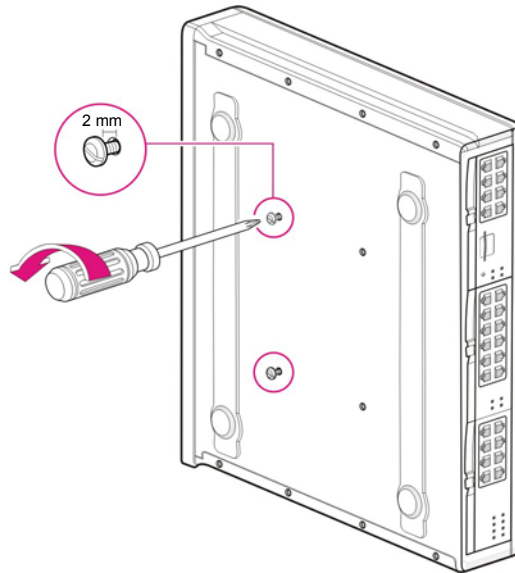

Figure 2.10 Installation on a Wall (5)

- 6) Tighten the mount locking screws into the remained two holes among the four screw holes on the bottom of the OfficeServ 7100 cabinet. At this point, do not tighten completely, but remain the untightened part about 2 mm.

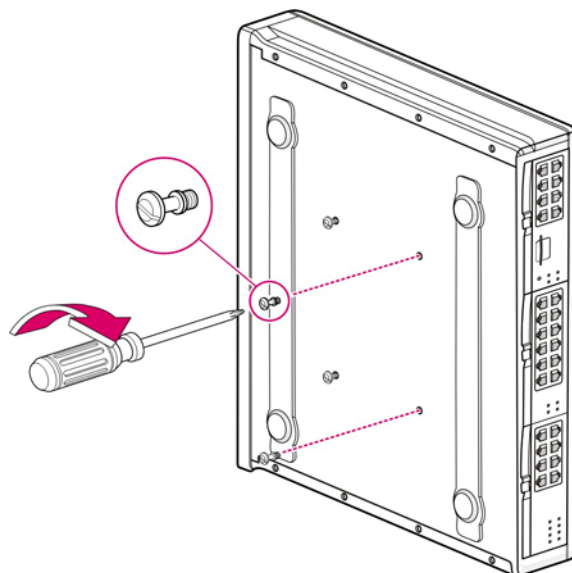

Figure 2.11 Installation on a Wall (6)

- 7) Align the screws on the bottom of the OfficeServ 7100 cabinet to the bracket holes, then pull down the cabinet to fix the cabinet completely.

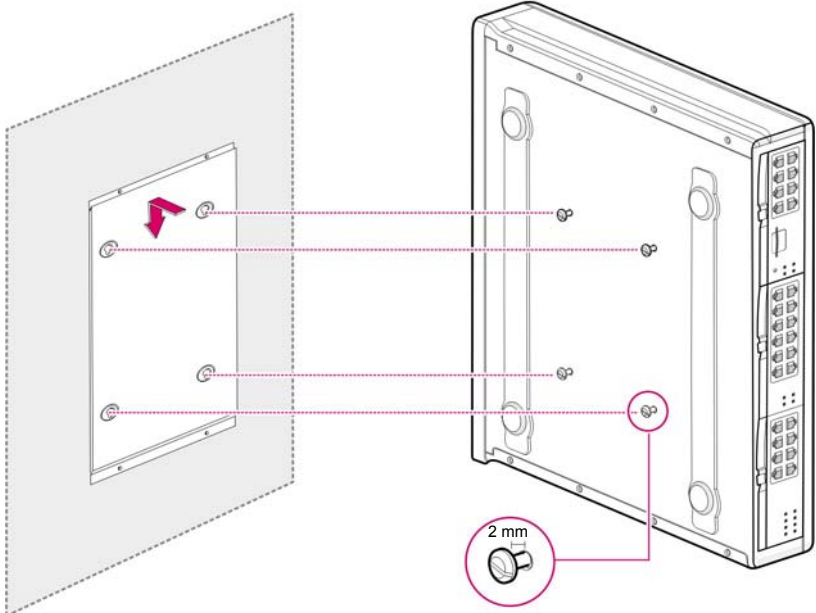

Figure 2.12 Installation on a Wall (7)

2.5 Connecting the Grounding Wire

This section describes how to connect an external grounding wire to the OfficeServ 7100 system.



External Grounding

External grounding is required to prevent human injuries or system damages caused by lightning, static electricity, or voltage surge.

The OfficeServ 7100 system has to be grounded by big electric wire more than a cross-sectional area is 4.0mm^2 . The Screw should be minimum 3.5 mm nominal thread diameter and Ring Terminal should be UL Listed Lug Terminal used.

As shown in the figure below, ground to the ground lug behind the OfficeServ 7100.

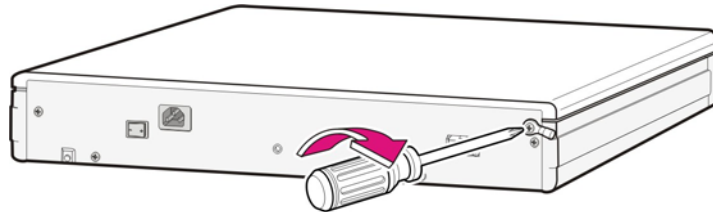

Figure 2.13 Grounding



Checking external grounding

After installing the OfficeServ 7100 system, make sure that the GND in the back side of the system cabinet is connected to the external ground for communication before the operation.

CHAPTER 3. Mounting and Replacing Boards

This chapter describes how to mount and replace various boards of the OfficeServ 7100 system.

3.1 Cabinet Configuration

The cabinet of the OfficeServ 7100 System has three slots that can install boards.

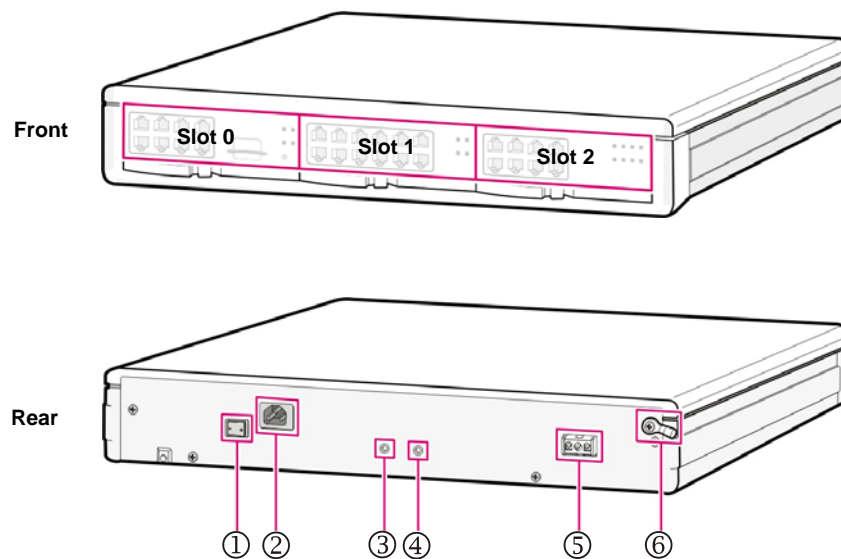

Figure 3.1 Front/rear View of OfficeServ 7100 Cabinet

Following boards are mounted on the slots according to the configuration of the OfficeServ 7100.

Table 3.1 Mountable Boards on Slots

Cabinet	Slot	Mountable Board
Control Part	Slot 0	MP10, MP11
Subscriber Part (UNI)	Slot 1 and Slot 2	- OS 7100 Card: UNI board - OS 7200 Card: 8/16DLI2, 8/16SLI2, 8COMBO, 8TRK, TEPRI, LIM, MGI, - OS7400 Card: TEPRI2, MGI64

The descriptions about each part on the rear of the cabinet are listed in the table below.

Table 3.2 Parts on the Rear Panel of the Cabinet

Part	Function
① Power Switch	Power on/off the OfficeServ 7100 system.
② Power I/O Switch	Connector for the power cable connection
③ AC LED	The LED indicates the input of AC power.
④ DC LED	The LED indicates the normal output of DC power.
⑤ Battery Socket	Socket to connect an external battery
⑥ Ground Lug	Lug for the ground of the system communication

3.2 Mounting Control Boards

This section describes how to set the switches of MP10/11 control board, mount the option boards, insert to the slots and connect MP10/11 board.

3.2.1 Setting Switches and Mounting Option Boards.

MP10/11 has the switches to set the board operation for the user's purpose and fitting with the system configuration. The way to set the switches and mount the boards are as follows:

- 1) Set S1 switch of the MP10/11 board as On and Pin 1 to Pin 4 of S2 switch as Off. Pin 6 to Pin 8 are set depending on the user's purpose.

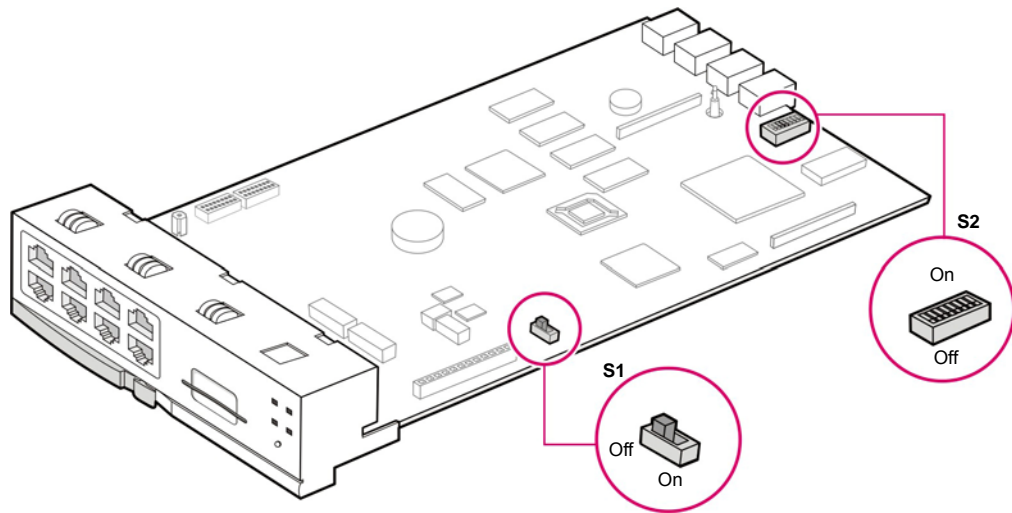

Figure 3.2 Setting Switches of MP10/11 Board

Table 3.3 Switches of MP10/11 Board

Switch	Description	
S1	Set S1 as On before mounting on the slot for memory backup. If switched On when the switch is Off, all data in the database are automatically initialized. To store the data in the database, operate the system after turning on the S1 switch.	
S2	SW1~SW4	the pins are set the country code that the system will be used.
	SW6~SW8	Sets the number of digits for C.O./extension lines and extension. [Not-used : Always default 3 digits] SW6-On: 4 digits for C.O. line Off: 3 digits for C.O. line SW7-On: 4 digits for an extension group Off: 3 digits for an extension group SW8-On: 4 digits for an extension number Off: 3 digits for an extension number

- 2) A modem board is mounted to connector P7/P8 of the MP10/11 board.
When mounting a modem board, the holes on the corners of the modem should be aligned fitting with the spacer.

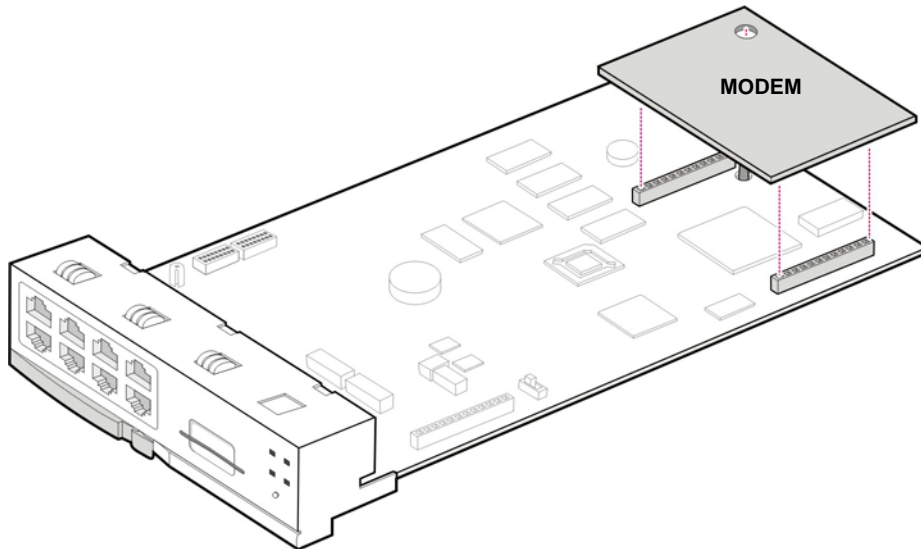
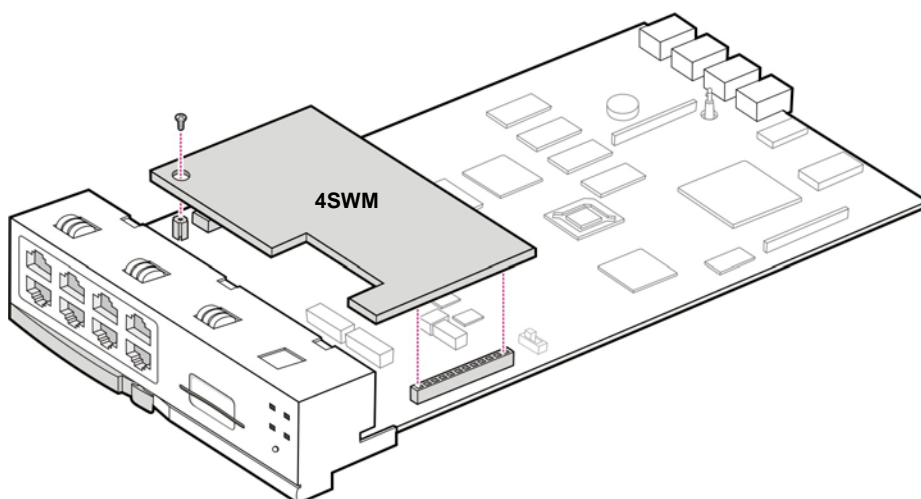

Figure 3.3 Mounting a Modem Board on the MP10/11 Board

4SWM or 4DLM can be mounted to connector P11, P12 and P13 of the MP10/11 board. Screws are basically locked to the support beside P13. Unscrew and position the screws to the connector direction of 4SWM or 4DLM before mounting 4SWM or 4DLM. After that, tighten the screws fitting with the grooves of 4SWM/4DLM.



3.2.2 Mounting Control Boards

Mount a control board to the slot 0 of the OfficeServ 7100 cabinet. For the locations of slot 0 to slot 2, refer to '3.1. Cabinet Configuration'.

Table 3.4 Control Board Types

Control Board	Mountable Slot
MP10/11	Slot 0 of the Basic Cabinet

Mount the MP10/11 board as follows:

- 1) Check if the MP10/11 board to be mounted is damaged.



Caution for the power when mounting boards

Check if the cabinet power is off when mounting boards on slots. Inserting or ejecting a board while the power is on may damage the board or cause fire.

- 2) Align the MP10/11 board to the guardrail of slot 0 of the basic cabinet, and slide the board into the slot with care.

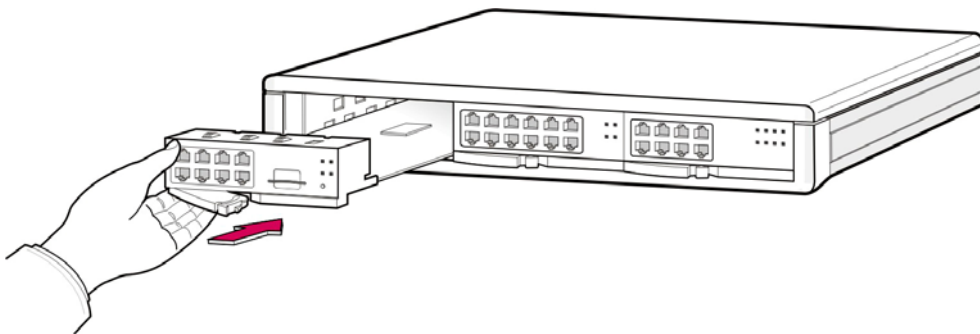

Figure 3.4 Mounting the Control Board to Slot 0

- 3) Press and lock the lever on the front panel of the MP10/11 board to fully insert to the connector of the OfficeServ 7100 connector.

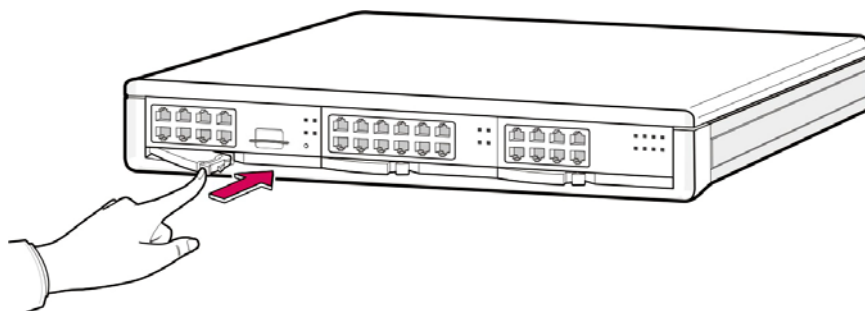

Figure 3.5 Inserting the Control Board to a connector of the Main Board

3.3 Mounting Interface Boards

This section describes how to set jumpers and switches of an interface board, how to mount optional boards to an interface board, and how to mount interface boards into slots.

3.3.1 Setting Switches and Mounting Optional Boards

These interface boards are divided into the boards to set switches or jumpers and the boards to mount option boards.

Table 3.5 Interface Board for Switches/Jumper Setting

Interface Board	Jumper/Switch Setting	Jumper/Switch Function
TEPRI	S1(SW1~SW8)	Setting E1, T1/E1/PRI, 24B+D/24B, User/Network and 17H/13H
TEPRI2	S2(1~4) S3(1~4)	Setting T1, E1, T1/E1/PRI, 24B+D/24B, User/Network and 1AH



NOTE

TEPRI(a/2) Cards is only support E1(1) PRI function, but not supports for E1(T1) Digital Trunk function.

Table 3.6 Interface Boards that can mount option boards

Interface Board	Option Board
MP10(MP11)	4DLM or 4SWM, MODEM
UNI	4TRM, 2BRM, 4DLM, 4SLM



NOTE

4SWM Module board is only support 100M LAN interface, but not supports for 10M LAN interface.

4TRM Module board is only support DTMF dialing, but not supports for Dial Pulse dialing. 8TRK Cards is support DTMF and Dial Pulse dialing.

3.3.1.1 Mounting UNI Board

The UNI board has three connectors to mount option boards and the mountable modules are 4TRM, 2BRM, 4DLM and 4SLM. For user's purpose, up to three modules can be mounted regardless of the type of the option module. Module1, Module2 and Module3 are positioned on the basis of the front panel of the UNI board, and the interface of the corresponding module is marked on the front panel of the UNI board.

Align the module to be mounted to the top connector(16-pin connector). After that, match the bottom connector(100-pin connector). Mount two connectors grasping both connectors. Lock the supporter between the grooves and the top of each option board with screws.

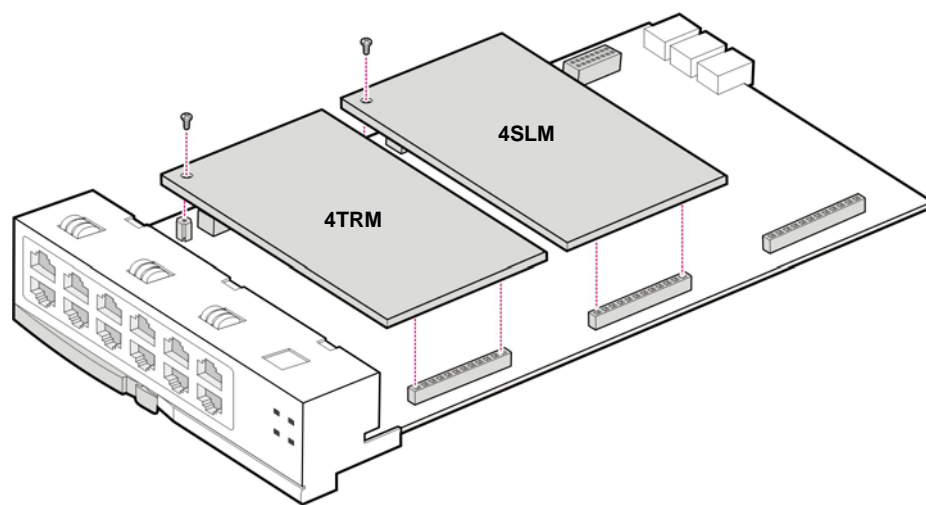

Figure 3.6 Mounting the UNI Board

3.3.1.2 TEPRI Boards

Set the S1 switch of the TEPRI board as follows:

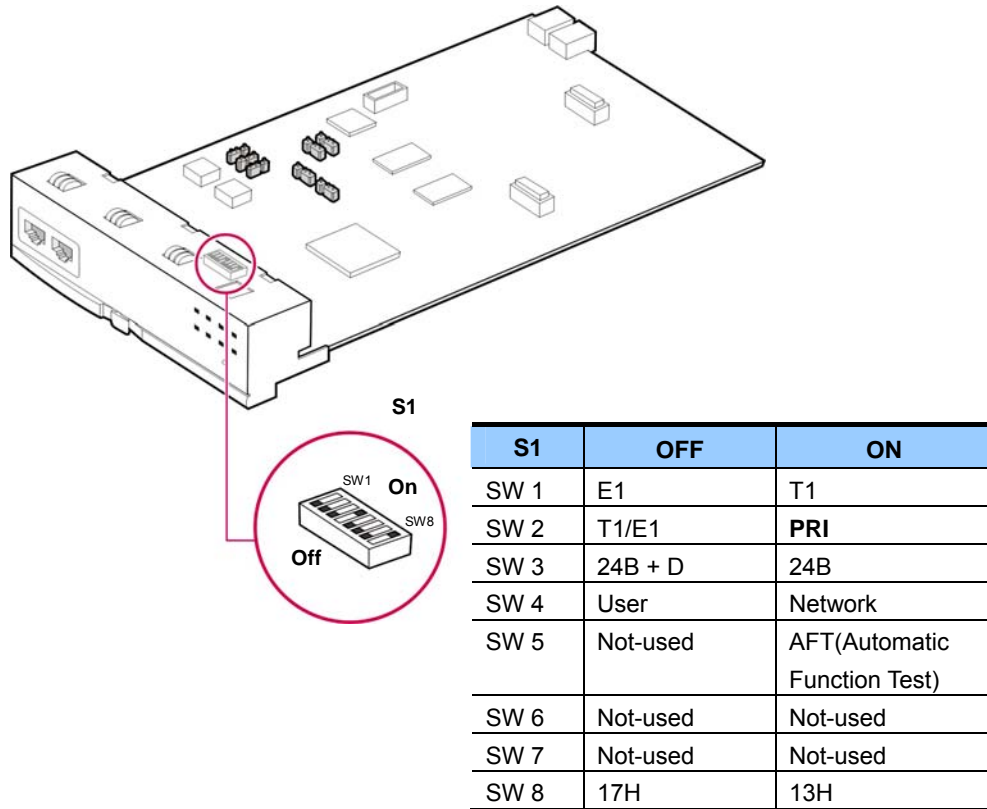

Figure 3.7 Setting the Switch of the TEPRI Board

3.3.1.3 TEPRI2 Board

T1E1PRI2(TEPRI2) board, which provides a digital C.O. line, supports two ports for each E1, T1 and ISDN PRI and provides the Q-SIG function.

Set S2 and S3 switches and jumpers of the TEPRI2 board as follows:

Setting Switches

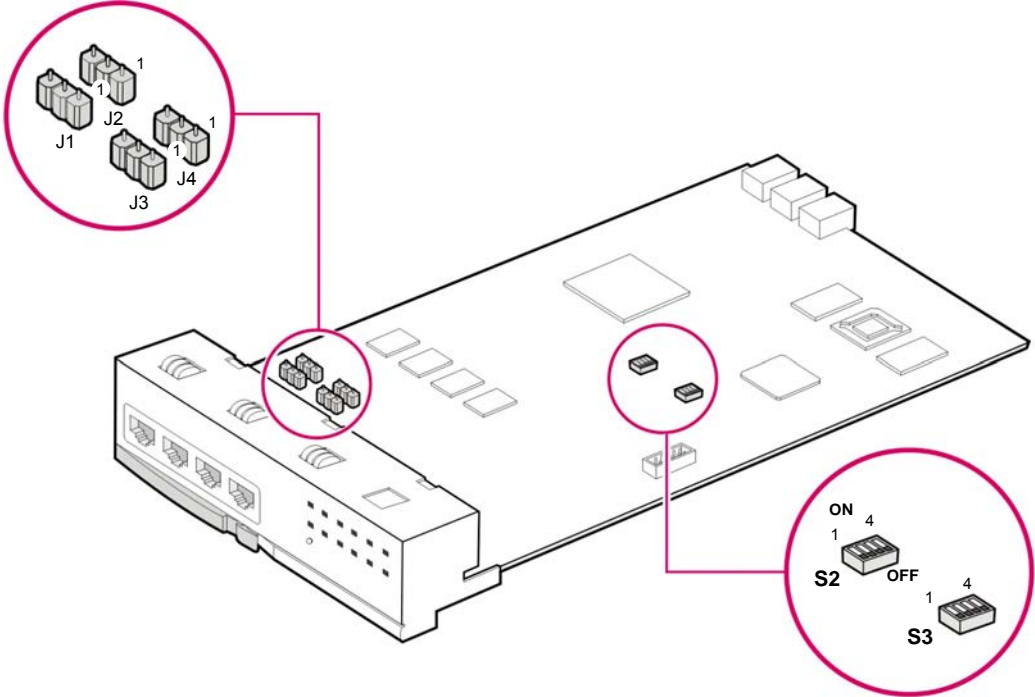

S2	OFF	ON
1	E1	T1
2	T1/E1	PRI
3	24B + D	24B
4	User	Network
S3	OFF	ON
1	Not-used	Not-used
2	T1/E1	PRI
3	24B + D	24B
4	User	Network

Figure 3.8 Setting Switches of the TEPRI2 Board

Setting Jumpers

J1, J2, J3 and J4: Connect #1 and #2 for E1 cable, #2 and #3 for T1 cable

3.3.1.5 PLIM Board

The OfficeServ 7100 system does not support the power to the PLM board. Therefore, the PLIM board does not support PoE and only performs the same function as that of the LIM board.

When the PLIM board is used, the board should be mounted after removing Shunt pin J1, J2 and J3 supplying the PoE Power.

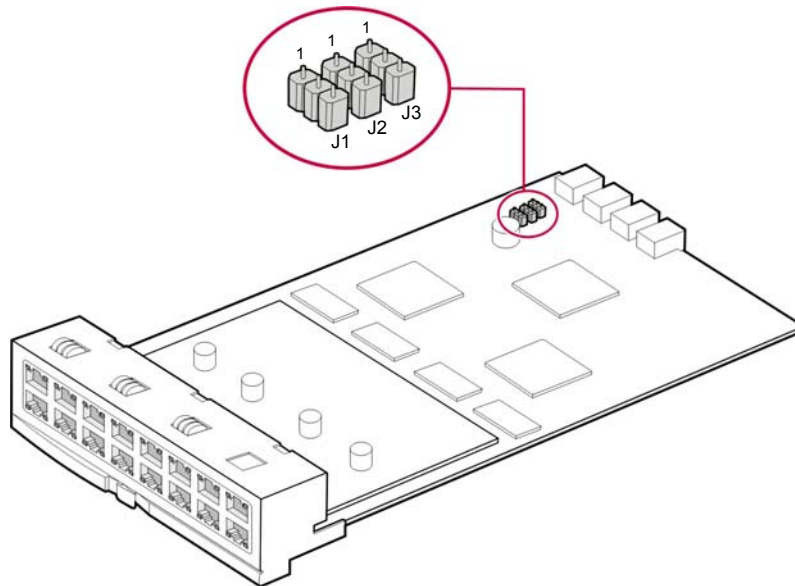

Figure 3.9 PLIM Board

3.3.2 Mounting Interface Boards to Slots

The interface boards are mounted to Slot 1 and Slot 2 of the cabinet. The available slot positions '3.1 Cabinet Configuration'.

Table 3.7 Interface Board Types and Available Slots

Category	Interface Board	Slots Available
Voice C.O. line	TEPRI, TEPRI2	Slot 1 and Slot 2 of the cabinet
	8TRK, UNI	Slot 1 and Slot 2 of the cabinet
Voice extension	16DLI2, 8DLI, 16SLI2, 8SLI, 8Combo, UNI	Slot 1 and Slot 2 of the cabinet
Data voice application	MGI, MGI64	Slot 1 and Slot 2 of the cabinet
	LIM	Slot 1 and Slot 2 of the cabinet



NOTE

References

For the detailed features and functions for each interface board, refer to 'OfficeServ 7200 System manual'.

The Procedure for mounting the interface board to each slot is as follows:

- 1) Check the exterior of the interface board for any damages.
- 2) Align each Interface board to the guardrail of the universal slot of the OfficeServ 7100 basic cabinet or expansion cabinet, and slide the Interface board into the slot.

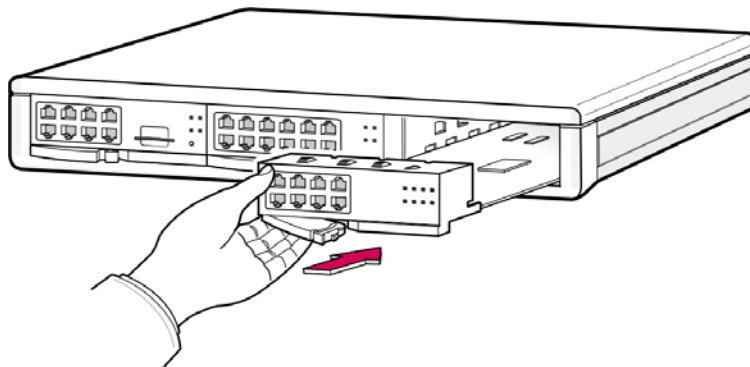

Figure 3.10 Mounting an Interface Board on a Slot

- 3) Press and lock the lever on the front panel of the interface board to fully insert to the connector of the OfficeServ 7100 main board.

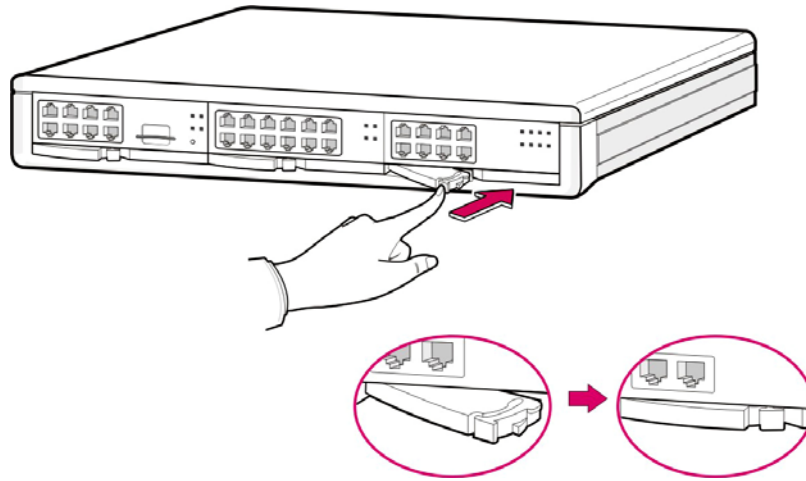

Figure 3.11 Inserting a control Board to the Connector of the Main Board

3.4 Connecting Power Fail Transfer

4TRM and 4SLM option boards are no Power Fail Transfer function.

If AC power is fails while battery is not connected, connect a power fail transfer circuit by connecting C.O. lines to extensions.

If a pair of trunk lines(8TRK) is connected to pin1 and pin2 of the first port in 16SLI2 or 8SLI, the lines are connected to a typical phone through Pin 4 and 5 in 8TRK.

In power failure, emergency calls can be available since the C.O. line is directly connected to the phone by the internal relay operation.

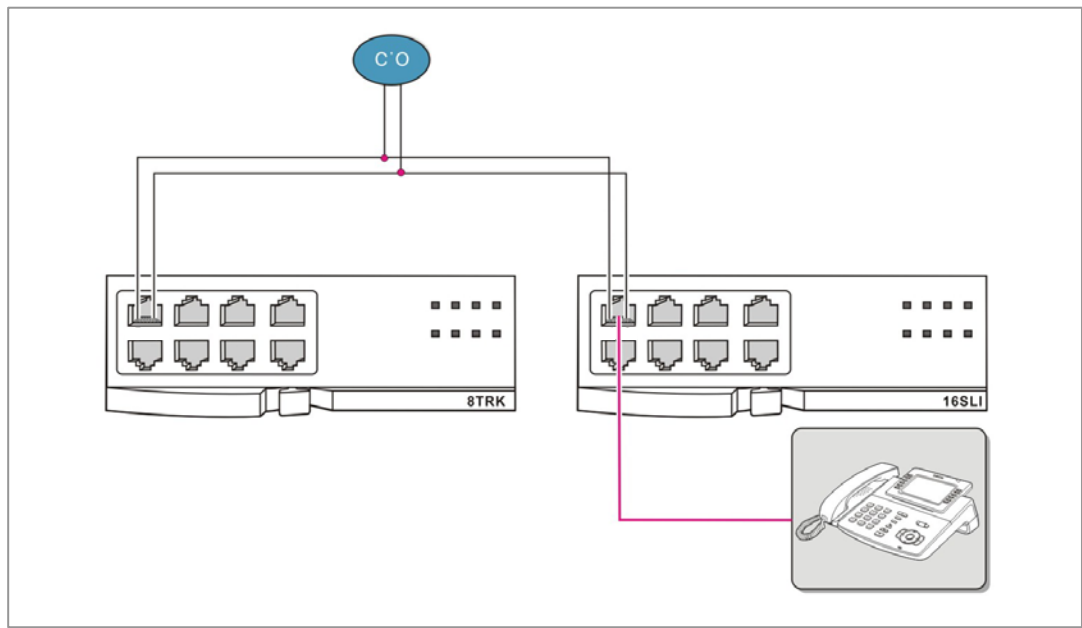

Figure 3.12 Connecting Power Fal Connection to a 16SLI2/8SLI Board

3.5 Replacing Boards

If the OfficeServ 7100 system fails to operate normally due to an error on the power supply board, control board, or interface board, replace the board to a new one.



Removing Cables

Replace a board after removing all cables connected to the board.

The procedure for replacing a board mounted in a slot of a cabinet is as follows:

- 1) Turn off the power of the cabinet equipped with the board to be removed.

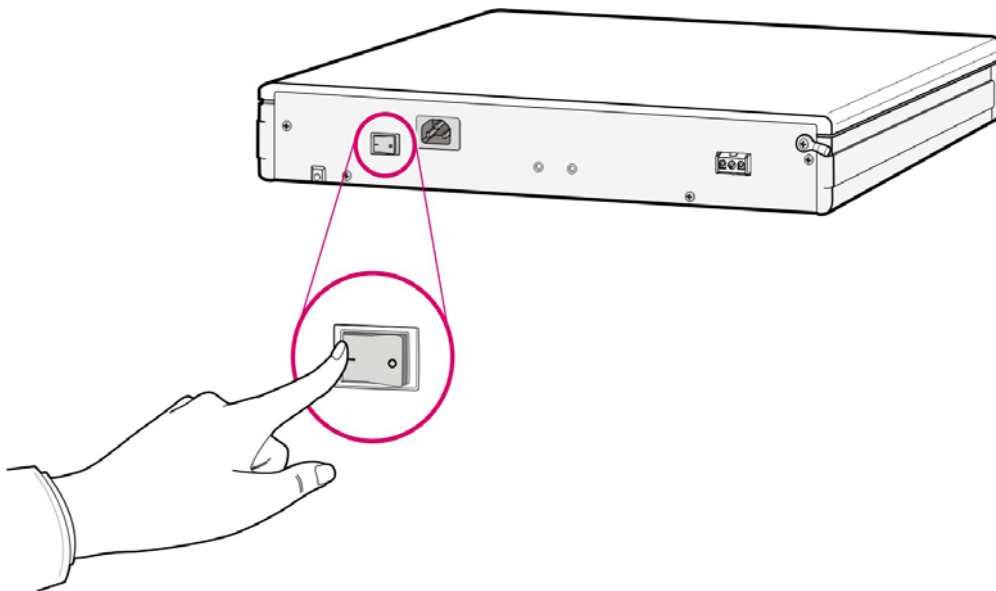

Figure 3.13 Turning the Cabinet Power Off

- 2) Extract the board by pulling the lever of the board carefully.

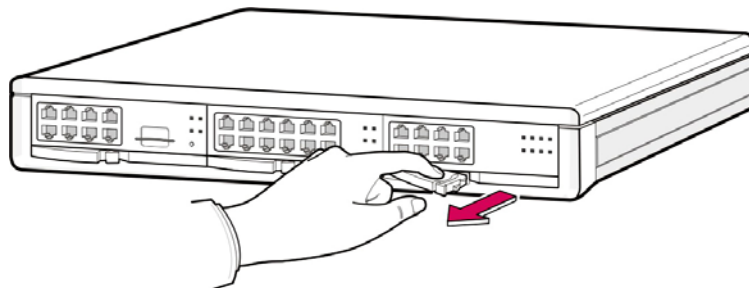

Figure 3.14 Removing a Board

- 3) Align the new board to the guardrail of the slot, and slide the new board into the slot. After then, lock the lever in the front panel of the board to fully insert into the connector of the OfficeServ 7100 main board.

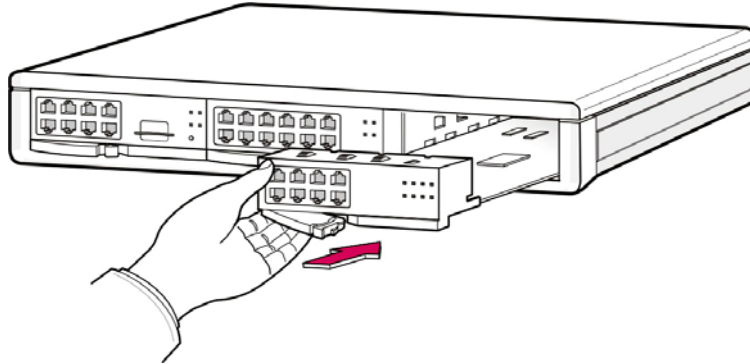

Figure 3.15 Replacing a New Board



This page is intentionally left blank.

CHAPTER 4. Connecting External Batteries

This chapter describes how to connect external batteries.

4.1 Cautions for Connecting External Batteries

- External batteries are required to ensure stable operation of the OfficeServ 7100 system in case a power failure occurs. The rated capacity of an external battery is DC 48V per cabinet. Batteries should be connected to each cabinet to guarantee safety and a fuse(125 VAC, 5 A) should be positioned between the output terminal of the battery and the battery connector of the cabinet



Cautions for connecting an external battery

Do not connect external AC power to the system before connecting an external battery to the system. To do so, may cause electric shock for the system or the constructor.

Make sure that the polarities(+/-) between the external battery ant the system are equal.

To reduce risk of fire and injury to persons, use only a sealed nickel cadmium or lead-acid battery supply capable of handling a charge current of 0.25 A, a charge voltage of -54 V dc and a discharge rate of 26 Ah.

-

4.2 Connecting External Batteries

The procedure for using a battery cable to connect an external battery to the OfficeServ 7100 system is as follows:

- 1) Prepare the battery cable that was provided with the OfficeServ 7100 system. An end of this battery cable consists of a white line and a black line.
- 2) Connect the white line of the battery cable to the (+) terminal, and the black line to the (-) terminal of the battery. Then, connect the other end of the battery cable to the external battery socket on the rear panel of the OfficeServ 7100 cabinet. When using two or more OfficeServ cabinets, prepare as much external batteries as the number of cabinets and connect the batteries to each cabinet.

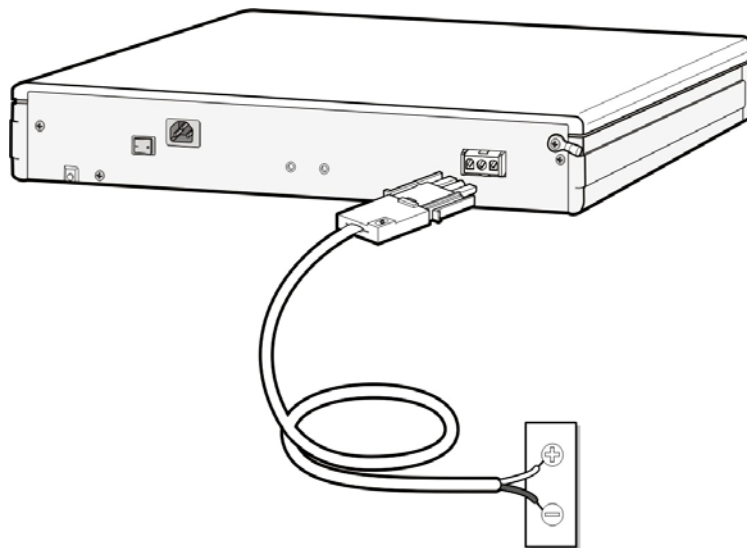

Figure 4.1 Connecting an External Battery

CHAPTER 5. Connecting the Power

This chapter describes how to connect power to the OfficeServ 7100 system.

5.1 Cautions when Connecting Power

When input power is normally supplied, the AC power is supplied to the Power Supply Unit(PSU), which charges the external battery. If the input power is interrupted, the system can be operated using the charged power of the external battery.

Cautions to be taken when connecting power to the OfficeServ 7100 system are as follows:

- AC power of the system only supports 230V.
- A single AC outlet should be used solely for the system's AC power. Sharing the AC power with other devices can cause noise or a voltage drop, resulting in a system malfunction or fire.
- Use a stable power source that can always supply AC power since instantaneous power failures can cause malfunctions or battery failures. Procedure for Connecting Power.

5.2 Connecting the Power

Single cabinet configuration

Use the power cable provided with the OfficeServ 7100 system to connect the input power terminal on the back panel of the basic cabinet to a grounded outlet.

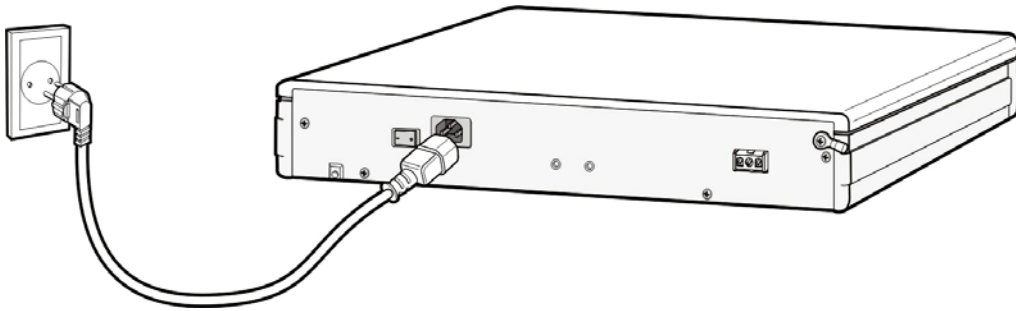

Figure 5.1 Connecting the Power (use of a cabinet)

CHAPTER 6. Connecting C.O. Line

This chapter describes how to connect the C.O. line to the OfficeServ 7100 system after installation.

6.1 Line Conditions

Cautions for connecting C.O. lines are as follows:

- Use the cables with AWG #24 or AWG #26 thickness.
- When wiring cables in high-humidity areas, remove moisture before wiring.
- Cables should be handled carefully to prevent any distortions or damages.
- Subscriber lines should be kept indoors if at all possible.
- Do not cable subscriber lines around any high-voltage power line.

Leak resistance for the C.O. line connected to the OfficeServ 7100 system is as follows:.

Table 6.1 Line condition of OfficeServ 7100

Line Condition	Leak Resistance
Leak Resistance between Lines	20 kΩ or higher
Leak Resistance Between Grounds	20 kΩ or higher

6.2 Connecting the C.O. Line

This section describes how to connect a common C.O. line(4TRM/2BRM of the UNI and 8TRK board) and PRI C.O. lines(TEPRI/TEPRI2 board).

6.2.1 Cautions to Connect the C.O. Line

Cautions to prevent bodily injuries and system damages when connecting the C.O. line are as follows:

- Do not connect the C.O. line in extreme weather conditions such as storm and lightning.
- Do not connect the C.O. line in areas with moisture.

6.2.2 Connecting Common C.O. Line

Use a pair of AWG #24(or AWG #26) cable to connect a common C.O. line to the terminal pin of a terminal box connected to the OfficeServ 7100 system equipped with a 4TRM or 2BRM board.



P1-P4 Ports
(RJ-45)

Pin No.	1	2	3	4	5	6	7	8
Function	-	-	-	C.O TIP	C.O RING	-	-	-

Figure 6.1 RJ-45 Port of 4TRM//8TRK Board

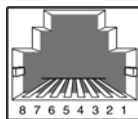

P1-P2 Ports
(RJ-45)

Pin No.	1	2	3	4	5	6	7	8
Function	-	-	TX +	RX +	RX -	TX -	-	-

Figure 6.2 RJ-45 Port of 2BRM Board

6.2.3 Connecting T1/E1/PRI

TEPRI boards can be connected to a T1/E1 C.O. line through a RJ-45 port.

As shown below, connect a T1 type C.O. line or an E1 type PRI C.O. line to the T1/E1/PRI port of the TEPRI/TEPRI2 built in the OfficeServ 7100 system.

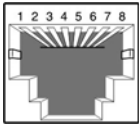

T1/E1/PRI Port
(RJ-45)

Pin No.	1	2	3	4	5	6	7	8
E1 Mode Function	-	-	-	Tx+	Tx-	-	Rx-	Rx+

Figure 6.3 RJ-45 Port of TEPRI Board

CHAPTER 7. Connecting Stations and Additional Equipment

This chapter describes how to connect various stations and additional equipment, such as analog/digital phones, door phones and door locks.

7.1 Connecting Stations

7.1.1 Cautions for Connecting Stations

Take the following cautions when connecting stations:

- Do not connect stations in weather conditions such as storm and lightning.
- Do not connect stations in a humid area.
- Comply with the manual of the station and with this document when reconnecting stations or changing connections.
- Connect stations to a pair of #24 AWG or #26 AWG cables.

The distances between stations and the OfficeServ 7100 system are as follows:

Table 7.1 Distance Between Stations and the System

Installation Distance	Standards
Digital Phone	Maximum 400 m(for AWG #24)
Analog Phone	Maximum 1 km(for AWG #24)
Door Phone	Maximum 400 m(for AWG #24)
AOM	Maximum 400 m(for AWG #24)

7.1.2 Connecting Analog Phones

Connect an analog phone to the 4SLM of the UNI board, 8SLI/16SLI2, 8COMBO or UNI board mounted on the OfficeServ 7100 system.

Connecting to the 4SLM of a UNI Board

Connect an analog phone to the ports of a 4SLM of the UNI board by using a pair of AWG #24 or AWG #26 cables.

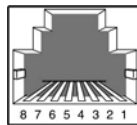

P1-P4 Ports
(RJ-45)

Pin No.	1	2	3	4	5	6	7	8
Function			-	SLI TIP	SLI RING	-	-	-

Figure 7.1 RJ-45 Port of 4SLM Board

Connecting to a 8SLI/16SLI2 Board

Connect an analog phone to the port of a 16SLI board by using a pair of AWG #24 or AWG #26 cables.

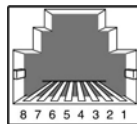

P1-P8 Ports
(RJ-45)

P1 Port

Pin No.	1	2	3	4	5	6	7	8
Function	PFT TIP (8SLI)	PFT TIP (8SLI)	-	SLI 1 TIP	SLI 1 RING	-	PFT TIP (16SLI2)	PFT TIP (16SLI2)

P2-P16 Ports

Pin No.	1	2	3	4	5	6	7	8
Function	-	-	-	SLI TIP	SLI RING	-		

Figure 7.2 RJ-45 Port of 16SLI2 Board

Connecting to a 8COMBO Board

Connect an analog phone to the ports of a 8COMBO board by using a pair of AWG #24 or AWG #26 cables.

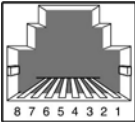

P1-P8 Ports
(RJ-45)

P1-P8 Ports

Pin No.	1	2	3	4	5	6	7	8
Function	-	-	-	SLI TIP	SLI RING	-		

Figure 7.3 RJ-45 Port of 8COMBO Board (for Analog Phone Connection)

7.1.3 Connecting Digital Phones

Connect a digital phone to the 4DLM of the UNI board, 8DLI, 16DLI2 and 8COMBO board.

Connecting to the 4DLM of a UNI Board

Connect an analog phone to the ports of a 4DLM of the UNI board by using a pair of AWG #24 or AWG #26 cables.

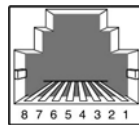

P1-P4 Ports
(RJ-45)

P1-P4 Ports

Pin No.	1	2	3	4	5	6	7	8
Function			-	DLI TIP	DLI RING	-	-	-

Figure 7.4 RJ-45 Port of 4DLM Board

Connecting to a 8DLI/16DLI2 Board

Connect a digital phone to the ports of a 8DLI board by using a pair AWG #24 or AWG #26 cables.

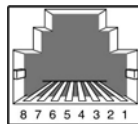

P1-P8(P16)
Ports
(RJ-45)

P1-P16 Ports

Pin No.	1	2	3	4	5	6	7	8
Function	-	-	-	DLI TIP	DLI RING	-	-	-

Figure 7.5 RJ-45 Port of a 8DLI (for a digital phone)

Connecting to a 8COMBO Board

Connect a digital phone to the ports of the 8COMBO board by using a pair AWG #24 or AWG #26 cables.

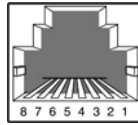

P1-P8 Ports
(RJ-45)

Pin No.	1	2	3	4	5	6	7	8
Function	-	-	-	DLI TIP	DLI RING	-		

Figure 7.6 RJ-45 Port of 8COMBO Board (for digital phone)



Maximum number of DS-5012L phones connectable

Up to eight DS-5012L phones can be connected to each DLI board(8DLI/16DLI2) of the OfficeServ 7100 system. If more than eight DS-5012L phones are connected to the DLI board, the power for all digital phones connected to the same board is blocked automatically. Up to 24 DS-5012L phones can be connected to the basic cabinet or the expansion cabinet.

7.1.4 Connecting IP Phones

IP phone is a phone that provides calls through Ethernet LAN. The interface between a digital phone connected to the OfficeServ 7100 system and an IP phone connected to LAN is as follows. In default, the MP10/11 board supports eight MGI channels. Therefore, IP phones are available even if additional MGI16/MGI64 boards are not mounted.

- 1) The connection between a digital phone and an IP phone is established or released using the IP address of the LAN connected to the OfficeServ 7100 system.
- 2) The digital phone connected to the OfficeServ 7100 system converts the analog voice data to PCM voice data and transmits the data to the MP10/MP11 or MGI boards via through 16 DLI2 board
- 3) PCM voice data is converted to packet data by the MP10/MP11 board and transferred to the IP phone.
- 4) The IP phone converts packet voice data to analog voice signals and displays the signals through a handset or a speaker.
- 5) Voice signals coming from the IP phone is converted to packet data and transmitted to the MP10/MP11 or MGI board in the same way. The MP10/MP11 or MGI board converts the packet voice data to PCM voice data and transmits the data to the digital phone through the 16DLI2 board. The digital phone converts and sends the PCM voice data to analog data.

Use after the MMC setting suitable for the system.

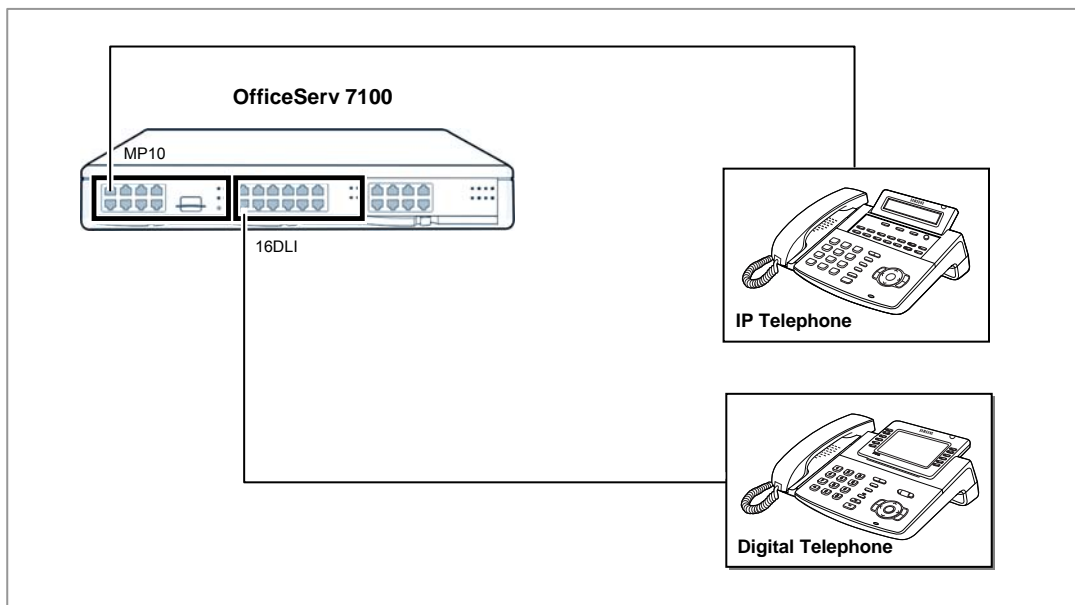

Figure 7.8 IP Phone Layout

7.1.4.1 Connecting Boards to Ethernet

LIM/MGI/MGI64/MP10/MP11/4SWM board can be connected to Ethernet by using an Ethernet cable



- LIM Board-All ports(P1~P16)
- 4SWM Board-Line Ports(P1~P4)
- MP10/11, MGI16/MGI64 Board-LAN Port

Pin No.	1	2	3	4	5	6	7	8
Function	Tx+	Tx-	Rx+	-	-	Rx-	-	-

Figure 7.9 RJ-45 Port of Ethernet Connection Board

7.1.5 Connecting to a Door Phone and a Door Lock

Connect a door phone and a door lock to the OfficeServ 7100 system by using a Door Phone Interface Module(DPIM). Connect a pair of #24 AWG or #26 AWG cables to the LINE port of DPIM and the ports of 8DLI/16DLI2/8COMBO/4DLM board of the OfficeServ 7100 system.

Connecting to 8DLI/16DLI2/4DLM Boards

Pin No.	1	2	3	4	5	6	7	8
Function	-	-	-	DLI TIP	DLI RING	-	-	-

Figure 7.10 RJ-45 Port of 8DLI/16DLI2/8COMBO/4DLM Boards (for Door Phone)

- 1) Connect the Door port of DPIM and the line port of DOOR BOX port.
- 2) When using an automatic door lock, connect the Lock port of the DPIM and the door phone contact point to the door lock.

The door lock contact point is designed to control low-voltage relay and uses 24 VDC and 100 mA.



NOTE

MMC Related

MMC 211 is used to assign call numbers to door phones.

7.2 Connecting Additional Equipment

This section describes how to connect optional equipment, such as Music on Hold(MOH)/Background Music(BGM) sources, external page devices and common bells, to the OfficeServ 7100 system.

7.2.1 Connecting MOH/BGM Equipment

The OfficeServ 7100 system offers music when while on hold.

The system provides internal tone/music and external music sources per C.O. or extension lines as the music source. The selection of internal/external music sources is performed through MMC 861. One external music source is provided while on hold, and the external music source is connected to the MISC port.

If a pair of MOH/BGM Source lines is connected to pin4 and pin5 of the MISC port in MP10(MP11).

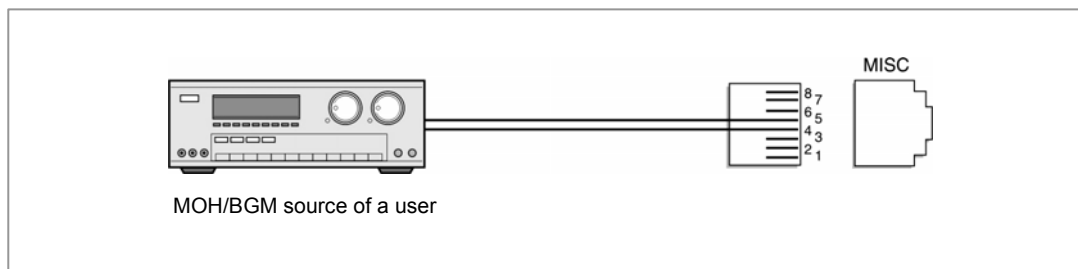

Figure 7.11 Connecting MOH/BGM Sources



NOTE

MMC Related

Select music sources for C.O. lines through MMC 408 and music sources for extensions through MMC 308. If external music source will be used, select this option through MMC 861 (default is internal).

7.2.2 Connecting External/Additional Page Equipment

Instead of an internal speaker, external broadcasting equipment, such as amps or speakers, and additional equipment that can broadcast page(ring) signals outside a building can be connected to the OfficeServ 7100 system. Connect external/additional page equipment to the MISC port of the MP10/MP11 board mounted on the OfficeServ 7100 system. The power of the external/additional page equipment should be separately connected. The OfficeServ 7100 system supports the channels for external broadcasting and one dry contact. **If a pair of External Page Equipment lines is connected to pin3 and pin6, Dry Contact 1 lines is connected to pin1 and pin2, Dry Contact 2 lines is connected to pin7 and pin8 of the MISC port in MP10(MP11).**

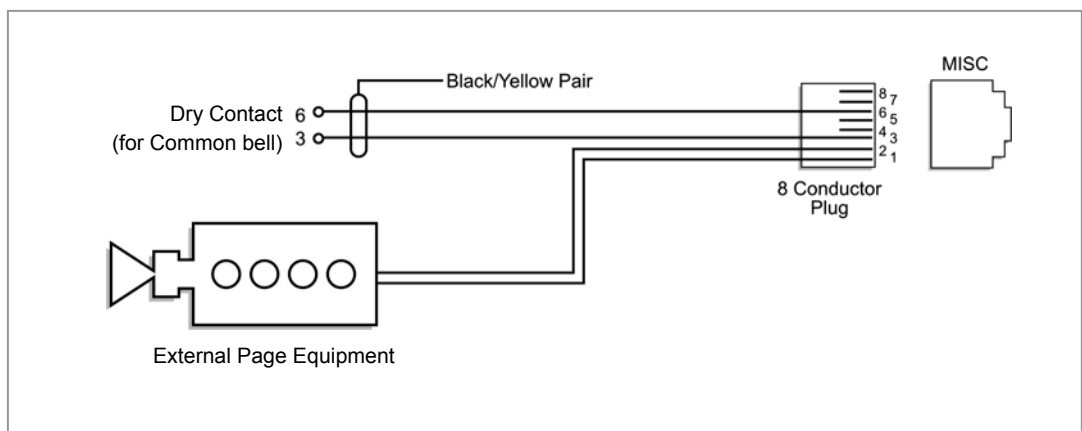

Figure 7.12 Connecting External/Additional Page Equipment



Dry Contact

Dry Contact is a switch that can connect or cut the power or line to external equipment.

7.2.3 Connecting Common Bell

Common Bell is the ring type. So, when a ring is received through an extension of a group, all extensions of the group also receive the ring.

To use common bell, connect the common bell to the MISC port mounted on the OfficeServ system. The OfficeServ 7100 system supports only one dry contact for the common bell.

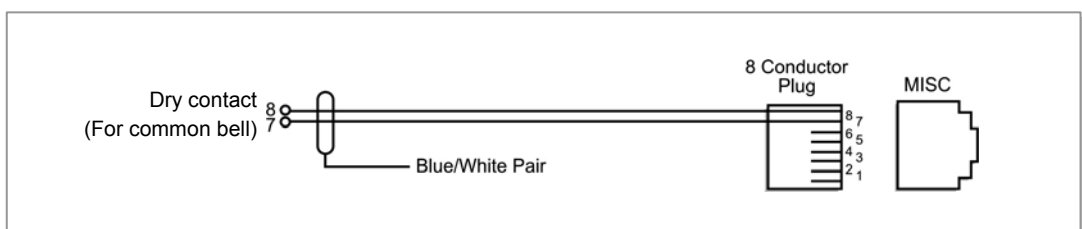

Figure 7.13 Connecting Common Bells

7.2.4 Changing System Setting

Since the OfficeServ 7100 system is equipped with the web server of WebMMC, it supports the remote access through the network. The system administrator can change the system setting after getting access to WebMMC by using a browser.

This section describes how to access the OfficeServ 7100 system.

If the in-housing network is established, connect LAN to the LAN port of the MCP board and attempt the access in a client PC.

Setting Network parameter by using the MMC830 program

Set the network parameter of the OfficeServ 7100 system. For the setting value of the network parameter, contact the network administrator.

- 1) Set the IP address of the OfficeServ 7100 system.
- 2) Set the subnet mask of the OfficeServ 7100 system.
- 3) Set the gateway address of the OfficeServ 7100 system.
- 4) Reset the board.



CHECK

About the board reset

To apply new setting, the board should be reset.

Getting access to WebMMC from a client PC

- 1) Execute your browser.(Internet Explorer 5.0 or higher)
- 2) Access WebMMC by using the LAN IP address.
Access address: [http://\[System LAN IP Address\]](http://[System LAN IP Address])

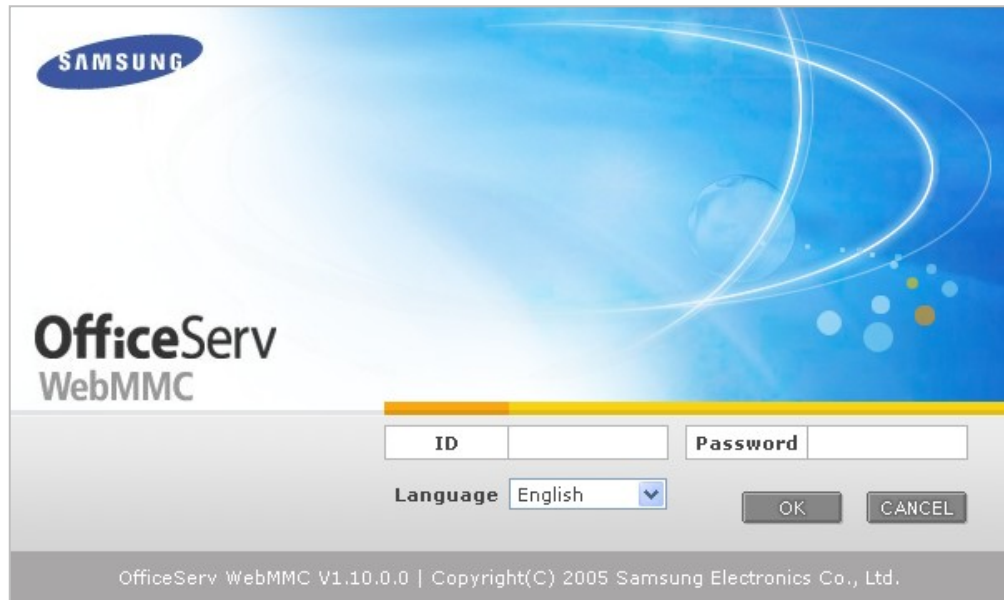

Figure 7.14 WebMMC Initial Screen

- 3) Enter your ID and password on the WebMMC initial screen, and click the [OK] button for login.

7.2.5 Connecting SMDR

The Station Message Detail Recording(SMDR) computer is used for recording call information and for calculating phone bills or displaying various analysis data based on the call data provided by the system.

The SMDR computer can be connected via the LAN port of the 4SWM board or the MP10/11 board built in the OfficeServ 7100 system.

SMDR system specification is as follows:

Table 7.2 Specification of the SMDR System

Category	Specification
Platform	IBM PC
CPU	Pentium 586 or higher
Operating System	Windows 95/98 r later
Main Memory	32 MB or more

If LAN is established within the company, connect LAN to the LAN port of the MP10/11 board and a SMDR computer to the LAN.

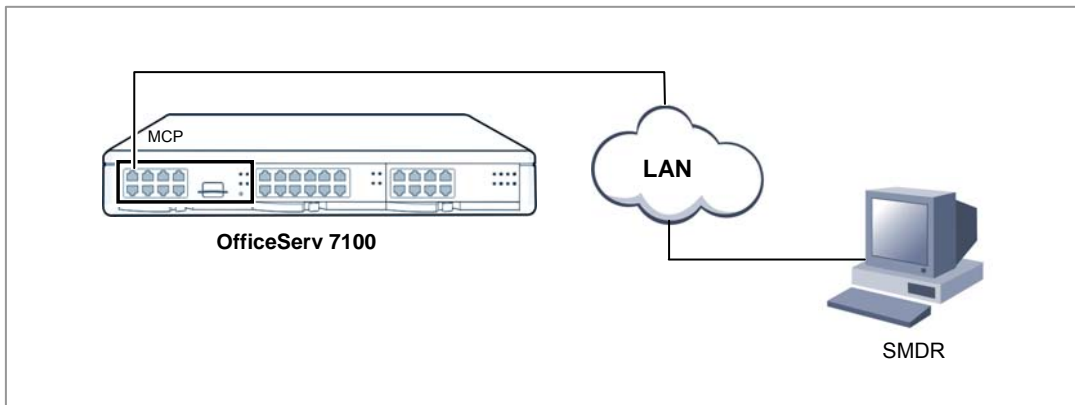

Figure 7.15 Connecting SMDR

7.2.6 Connecting Printers

The OfficeServ 7100 system can connect to printers. The system can print various call information or event information created by the system in real time whenever an event occurs.

If LAN is established within the company, connect LAN to the LAN port of the MP10/11 board and a printer to the LAN. If the 4SWM is built in the MP10/11, a printer can be connected to the LAN port of the 4SWM.

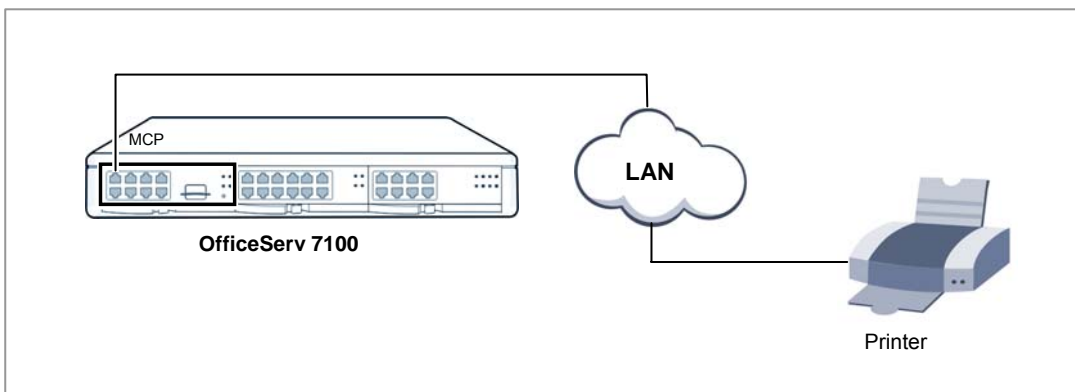

Figure 7.16 Connecting Printers



NOTE

MMC Related

After connecting a printer, execute MMC 804 and enter the I/O port through which the printer is connected.

CHAPTER 8. Starting the System

This chapter describes items to check before starting the OfficeServ 7100 system, the procedure for starting the system, and the procedure to test the operation of the system.

8.1 Pre-Check

This section describes items to check before starting the OfficeServ 7100 system.

8.1.1 Environment

- **Temperature**
Check if the room temperature is between 0°C and 40°C. If the room temperature is out of range from the normal operation temperature, install a heating/cooling device to maintain the normal operation temperature.
- **Humidity**
Check if the humidity of the room where the system is installed is between 10% and 90%. Take special caution since humidity affects the electric components and connectors of the system.
- **Direct Sunlight and Dust**
The room where the OfficeServ 7100 system is installed should be protected from direct sunlight and should have ventilation systems to prevent the system from malfunctioning due to dusts.

8.1.2 Safety Conditions

The building where the OfficeServ 7100 system is installed should have lightning rods and grounding to protect the system against lightning and electric leakage.

- Check if the OfficeServ 7100 system is not inclined and is maintained horizontally.
- Do not place devices that may cause electromagnetic interference near the system.
- Place a fire extinguisher near the system. Since spring coolers can seriously damage the system, use extinguishers such as Halor 1301 and Carbon Dioxide.
- Make sure that the input power of the OfficeServ 7100 system should be AC 230 V and do not use together with other electric devices, such as motors and compressors.
- Check if the AC voltage switch of the PSU is properly set according to the voltage of the input power, 230 VAC.
- Check if the grounding terminal on the rear panel of the system is properly connected to the external grounding.

8.2 Starting the System

The procedure for starting the OfficeServ 7100 system is as follows:

- 1) Check if the boards and cables are properly mounted and connected to the OfficeServ 7100 cabinet.
- 2) Turn on the power of the OfficeServ 7100 basic cabinet, and turn on the power of the expansion cabinet.
- 3) Check the LEDs for the MP10/11 boards mounted on the OfficeServ 7100 cabinet.
 - The RUN LED of the MP10/11 board turns green and the MC LED flashes when the system normally starts the booting process.
 - Once the booting is complete, the RUN LED of the MP10/11 board flashes green, and the SM LED stops flashing and remains lighted.
 - The RUN LED of the LCP board flashes when the power supply and processor status of the expansion rack is normal.



NOTE

If the Multi Media(MMC Card) is not detected

If the system cannot detect the multi media, the SM LED of the MP10/11 board might not light or flash. In such cases, turn off the power of the basic cabinet, replace the multi media and turn the power on again. If the problem continues, turn off the power of the basic cabinet and remove the MP10/11 board.

- 4) Check if the LED statuses of other interface boards are normal.
- 5) If the LED status of a MP10/11 or interface board is abnormal, turn off the power of the cabinet and turn the power on again.



NOTE

Board LED Status & Shut-down

- Refer to the 'OfficeServ 7100 System Manual' for LED statuses of each board.
- Shut-down is hardly required while operating the OfficeServ 7100 system. However, when shutting down the system due to reasons such as moving the system, turn off the power of the expansion cabinet, and turn off the power of the basic cabinet.

8.3 Numbering Extensions and C.O. Lines

Once the OfficeServ 7100 system is booted, the MP10/11 board verifies the boards mounted on each slot and saves this information as the default configuration of the system.

C.O. line numbers from 701 are sequentially assigned to the C.O. line board mounted on Slot 1 of the basic cabinet, and following numbers are continuously assigned to the next board of the next slot. This numbering process continues until the C.O. line numbers are assigned to all C.O. lines. However, only the numbers from 701 to 799 are assigned when using 3 digits

Extension numbers from 201 are sequentially assigned to the extension board mounted on Slot 1 of the basic cabinet, and following numbers are continuously assigned to the next extension board of the next slot. This numbering process continues until the extension numbers are assigned to all extensions. However, only the numbers from 201 to 349 are assigned when using 3 digits.

The last port of the first 8DLI or 16DLI2 board is assigned to the attendant group as default. All C.O. lines ring this attendant extension unless the default value is changed. Thus, a phone with an LCD panel should be connected to the last port of the first 8DLI board.

Numbers between 500-549 are assigned to an extension group.

The numbers of C.O. lines, extensions, or extension groups can be changed using the MMC 724 program.

8.4 Checking System Operation

After starting the OfficeServ 7100 system, check if the system is operating normally.

Check if the basic functions of the OfficeServ 7100 system, such as Station Call, Station Camp-On, C.O. Line Call, and C.O. Line Camp-On are properly executed.

8.4.1 Station Call Function

First, follow the procedure below and check if calls between stations are enabled:

- 1) Lift the handset of a station.
Verify the intercom dial tone.
- 2) Press an extension number.
Check if the dial tone stops.
- 3) Press all extension numbers.
Verify the ring back tone.
- 4) Once the recipient answers the call, check the call status.
- 5) Hang up the phone and call a busy station.
Verify the busy tone.

8.4.2 Station Camp-On Function

If a caller dials a number and the recipient is busy, this function automatically connects the recipient and the caller right after the recipient hangs up the call.

Follow the procedure below and check the Station Camp-On function:

- 1) Lift the handset of the test phone and dial a busy station.
Verify the busy tone.
- 2) Upon verifying the busy tone, press the hook flash button.
Check if the busy tone stops.
- 3) Press the reservation code.
Verify the confirmation tone.
- 4) Lift the handset of the test phone and dial a busy station.
Check if the test phone rings.
- 5) Lift the handset of the test phone.
Check if the ring stops and confirm the ring-back tone.
Check if the other phone rings.
- 6) Lift the handset of the other phone.
Check if the other phone stops to ring, if the ring-back tone of the test phone stops, and if the parties are normally connected.

8.4.3 C.O. Line Call Function

Follow the procedure below and check if outside calls are normally connected.

- 1) Lift the handset of the test phone.
Verify the intercom dial tone.
- 2) Press the C.O. line call code.
Verify the C.O. line dial tone.
- 3) Check if an error tone is activated for phones that do not support C.O. line calls.
- 4) Press an external number.
Verify the ring back tone.
- 5) Once the call is connected, check the call status.

8.4.4 C.O. Line Camp-On Function

If a caller presses a C.O. line code to make an outside call and all C.O. lines are busy, this function reserves a C.O. line and notifies the caller if the C.O. line becomes available.

Follow the procedure below and check the C.O. Line Camp-On function.

- 1) Lift the handset of the test phone and press a C.O. line code.
Verify the C.O. line dial tone.
- 2) Check if a busy tone rings when all C.O. lines are busy.
- 3) Upon verifying the busy tone, press the hook flash switch of the test phone.
Check if the busy tone stops.
- 4) Press the code number of the C.O. line Camp-On function.
Verify the confirmation tone.
- 5) Replace the handset of the test phone and make the C.O. line idle.
Check if the test phone rings and if the C.O. line becomes busy.
- 6) Lift the handset of the test phone.
Check if the test phone stops to ring and verify the intercom dial tone and the C.O. line dial tone.



ABBREVIATION

4

4SWM	4 port Switch Module
4TRM	4 port Trunk Module
4DLM	4 port DLI Module
4SLM	4 port SLI Module

A

AC	Alternating Current
AFT	Automatic Function Test
AOM	Add On Module
AP	Access Point
AWG	American Wire Gauge

C

CTI	Computer Telephony Integration
-----	--------------------------------

D

DC	Direct Current
DLI	Digital Line Interface
DPIM	Door Phone Interface Module
DSL	Digital Subscriber Line

G

GND	Ground
-----	--------

H

HYB	Hybrid
-----	--------

I

IP	Internet Protocol
----	-------------------

K

KDB Ke yset Daughter Board

L

LAN Local Area Network
LCD Liquid Crystal Display
LED Light Emitting Diode
LIM LAN Interface Module
PLIM LAN Interface Module with PoE feature

M

MP10 Main Control Processor for OfficeServ 7100
MP11 Main Control Processor with Router for OfficeServ 7100
MGI16 16Channel Media Gateway Interface
MGI64 64Channel Media Gateway Interface
MMC Man Machine Command
MIS Miscellaneous

P

PC Personal Computer
PCM Pulse Code Modulation
PRI Primary Rate Interface
PSU Power Supply Unit

S

SLI Single Line Interface
SMDR Station Message Detail Recording

T

TEPRI2 T1E1PRI
TRK Trunk
UTP Unshielded Twisted Pair

W

WAN Wide Area Network
WBS Wireless Base Station
WIM Wide Area Network Interface Module
WIMD WAN Interface Module Daughter board
WIP Wireless Local Area Network IP
WLI Wireless Local Area Network Interface

OfficeServ 7100
Installation Manual

©2006 Samsung Electronics Co., Ltd.

All rights reserved.

Information in this manual is proprietary to SAMSUNG Electronics Co., Ltd.

No information contained here may be copied, translated, transcribed or duplicated by any form without the prior written consent of SAMSUNG.

Information in this manual is subject to change without notice.

